



HES

HOME ELECTRO SYSTEM

OPERATION AND INSTALLATION

TECHNICAL DATA SHEET

brine-to-water type heat pump

Models:

HES ECO-G 20

HES ECO-G 27

HES ECO-G 40

HES ECO-G 52

HES ECO-G 66



CONTENTS | OPERATION

CONTROL

1. 1. General instructions.....	4
1.1 Related documents	4
1.2 Safety instructions.....	4
1.3 Other designations in this documentation	4
1.4 Units of measurement	4
2 Safety.....	5
2.1 Intended use.....	5
2.2 Safety instructions.....	5
3. Description of the device.....	5
4. Control.....	5
5. Maintenance and care.....	6
6. Troubleshooting	6
6.1 Other problems.....	6

MOUNTING

7. Safety	7
7.1 General safety instructions.....	7
7.2 Regulations, standards and provisions.....	7
8. Description of the device	7
8.1 Working principle	7
8.2 The scope of delivery	7
9. Preparatory activities.....	11
9.1 General information	11
9.2 Electrical installation	12
9.3 Intermediate storage.....	12
10. Installation	12
10.1 Handling.....	12
10.2 Installation.....	13
10.3 Dismantling of cladding parts	13
10.4 Installation of the heat source circuit (salt solution)	14
10.5 Connection of heating circuits.....	15
10.6 Electrical connection.....	16
10.7 Installation of cladding elements	18
11. Start up.....	18
11.1 Monitoring before commissioning of the heat pump control device	18
11.2 Commissioning of the heat pump control device.....	19

11.3 Setting the graphical heating characteristics at the initial putting
into operation 19

11.4 Device transfer 20

11.5 Control and operation 20

12. Decommissioning..... 20

13. Maintenance and cleaning..... 20

14. Troubleshooting 21

14.1 Elements on the IHPC module..... 21

15. Specifications..... 22

15.1 Connections and dimensions in the models HES ECO-G20 and HES ECO-G27 22

15.2 Connections and dimensions in the models HES ECO-G40, HES ECO-G52, HES ECO-G66 23

15.3 Electrical circuits 24

15.4 HES ECO-G 20 Power Diagram 33

15.5 HES ECO-G 27 Power Diagram 34

15.6 HES ECO-G 40 Power Diagram 35

15.7 HES ECO-G 52 Power Diagram 36

15.8 HES ECO-G 66 Power Diagram 37

15.9 Parameter Table..... 38

16. Commissioning protocol..... 40

WARRANTY

WARRANTY | ENVIRONMENTAL PROTECTION AND DISPOSAL 43

CONTROL

1. GENERAL INSTRUCTIONS

The «Operation» chapter is intended for users and specialists.

The «Installation» chapter is intended for specialists.



INSTRUCTION

Please read this manual carefully and save it before starting operation. If necessary, hand this manual over to the next user.

1.1 Related documents

Heat Pump Control Device Operation And Installation Instructions Operation And Installation Instructions For All Components Included In The Installation Equipment.

1.2 Safety instructions

Additional components are not included in the device package.



1.2.1 Structure of safety instructions



SIGNAL WORD Type of danger

Here are the possible consequences of non-compliance with the safety instructions and measures to prevent danger.

1.2.1 Symbols, type of danger

Symbol	Type of danger
	Injury
	Electric shock

1.2.2 Сигнальные слова

Signal word	Value
DANGER	Instructions that may lead to serious injury or death if not followed.
WARNING	Instructions that may result in serious injury or death if not followed
CAUTION	Instructions that may result in moderate or minor injuries if not followed.

1.3 Other designations in this documentation



INSTRUCTION

The instructions are limited to horizontal lines above and below the text. General instructions are marked by the symbol next to them.

- Read the instructions carefully.

Symbol	Type of danger
	Equipment damage and environmental damage

Symbol	Type of danger
	Disposal of the device

► This symbol indicates the need to perform certain actions. The actions required are described step by step.

1.4 Units of measurement



INSTRUCTION

Unless otherwise indicated, all dimensions are given in millimeters.

SAFETY

2. Safety precautions

2.1 Intended use

The device is designed for heating rooms, taking into account the operational specifications given in the «Technical Characteristics» chapter. The device is intended for household use. The user does not need to be instructed for its safe maintenance. It is possible to use the device not only in everyday life but also, for example, in small enterprises, provided that the same operating conditions are met. Any other use of this device not mentioned in this manual is not considered intended use. Intended use also implies compliance with the provisions of this manual. If changes are made to the device or it is upgraded, all warranty obligations become invalid.

The device is designed to heat buildings.

2.2 Safety instructions

The following safety instructions and regulations must be followed:

- ▶ Electrical and heating circuit installation can only be carried out by certified, qualified specialists or technical staff of our service department.
- ▶ The specialist is responsible for compliance with the applicable rules during installation and initial commissioning.
- ▶ The device should only be used fully assembled with all safety devices installed.
- ▶ The device should be protected from dust and contamination during installation.



RISK of injury

The device should be operated by children or persons with physical or mental disabilities only under supervision or after an appropriate briefing conducted by a person responsible for their safety.

Do not allow children to play with the device!

3. Description of the device

HES ECO-G is a heat pump for a heating system that can be operated as a brine-water type heat pump. The heat pump takes heat from the coolant (salt solution) at a low-temperature level, which is then given to the water in the heating circuit at a higher temperature along with the energy absorbed by the compressor. Depending on the temperature of the heat source, the mains water can be heated to a supply temperature of +58 °C.

It is possible to use HES ECO-G as a module.

4. Control

The heat pump is controlled exclusively by the HES heat pump control system. Therefore, please take into account the instructions given in the «Operation» chapter of the manual for the HES heat pump control system operation and installation.

5. Maintenance and care



DAMAGE TO EQUIPMENT OR SYSTEM

Maintenance work, such as checking electrical fuses, should only be carried out by a specialist.

A wet cloth is enough to ensure proper maintenance of plastic and metal parts. Do not use abrasive or corrosive cleaning products!

Please protect the device from dust and contamination during installation.

6. Troubleshooting



The fault	Cause	Remedy
There is no hot water or the heating system remains cold.	The fuse is faulty.	Check the fuses of the building's electrical network.

6.1 Other problems

If it is impossible to fix this problem on your own, please contact a specialist. You need to tell him the numbers indicated on the nameplate to get help more quickly. The nameplate is located on the device in front of the right or left side panel of the device.

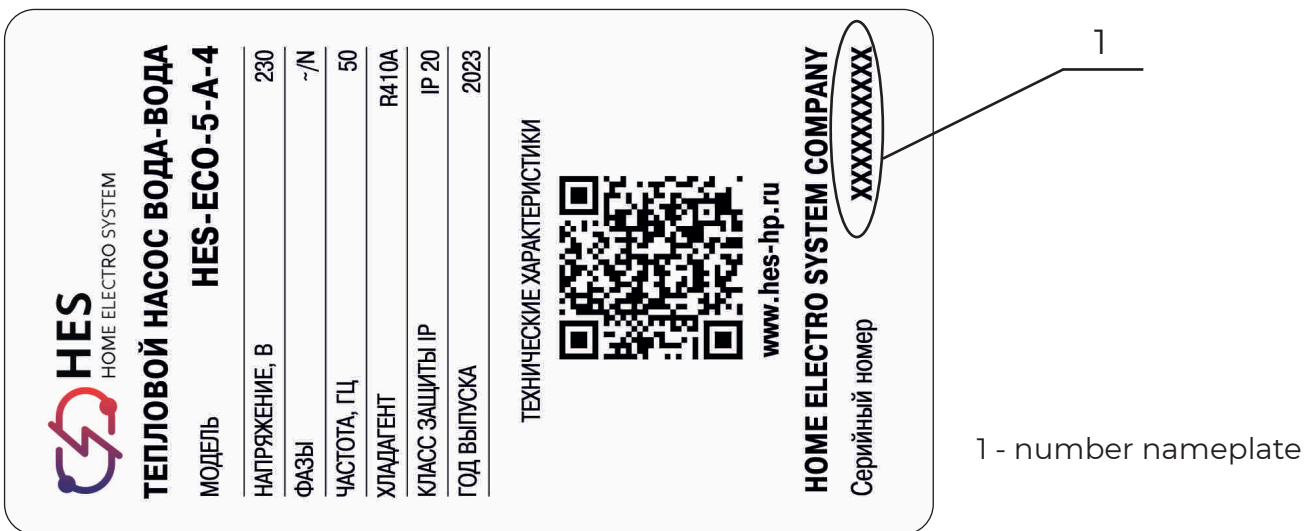
Example of a nameplate



		ТЕПЛОВОЙ НАСОС ВОДА-ВОДА МОДЕЛЬ HES-ECO-5-A-4
НАПРЯЖЕНИЕ, В	230	
ФАЗЫ	~/N	
ЧАСТОТА, ГЦ	50	
ХЛАДАГЕНТ	R410A	
КЛАСС ЗАЩИТЫ IP	IP 20	
ГОД ВЫПУСКА	2023	
ТЕХНИЧЕСКИЕ ХАРАКТЕРИСТИКИ  www.hes-hp.ru		
HOME ELECTRO SYSTEM COMPANY Серийный номер		XXXXXXXXXX

1 - number nameplate

MOUNTING

7. SAFETY PRECAUTIONS

Installation, start-up, as well as maintenance and repair of the device must be carried out only by a qualified specialist.

7.1 General safety instructions

We guarantee the perfect operation of the device and the safety of operation only if you use original accessories and spare parts.

7.2 Regulations, standards and provisions



INSTRUCTION

You have to comply with all national and regional regulations and rules.

8. DESCRIPTION OF THE DEVICE

8.1 Working principle

The ambient heat is taken from the heat source through a heat exchanger (evaporator) located on the side of the heat source. The energy absorbed in this case, together with the energy of the compressor drive, is transferred to the liquid of the heating circuit in a heat exchanger (condenser) located on the heating side. Depending on the heating load, the mains water of the heating system can be heated up to +58 °C.

Hot water is prepared through a heat exchanger built into the storage water heater.

8.2 The scope of delivery

8.2.1 The main components of the heat pump

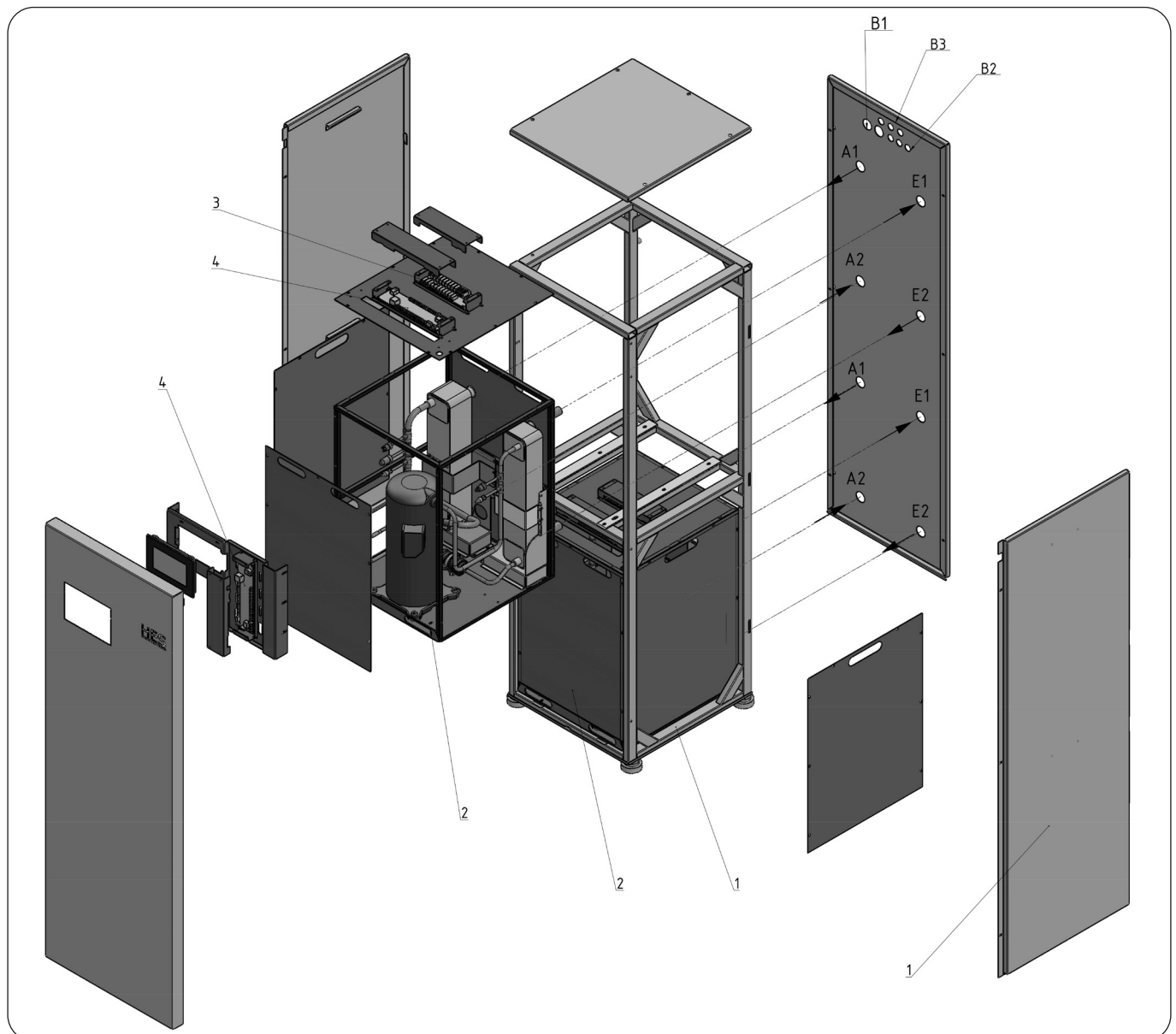

- 1 - HES ECO-G heat pump
- 2 - «Hydraulic assembly»
- 3 - Electric switchboard
- 4 - «Board housing 207x72»
- 5 - «Board housing 275x72»

Source of heat

- A1 - feed line;
- A2 - return line.

Heating

- E1 - Refrigerant supply to the condenser;
- E2 - Refrigerant return from the condenser.

Electrical Connection

- B1 - wiring input;
- B2 - is the input for the electric cable;
- B3 - is the safety kit.

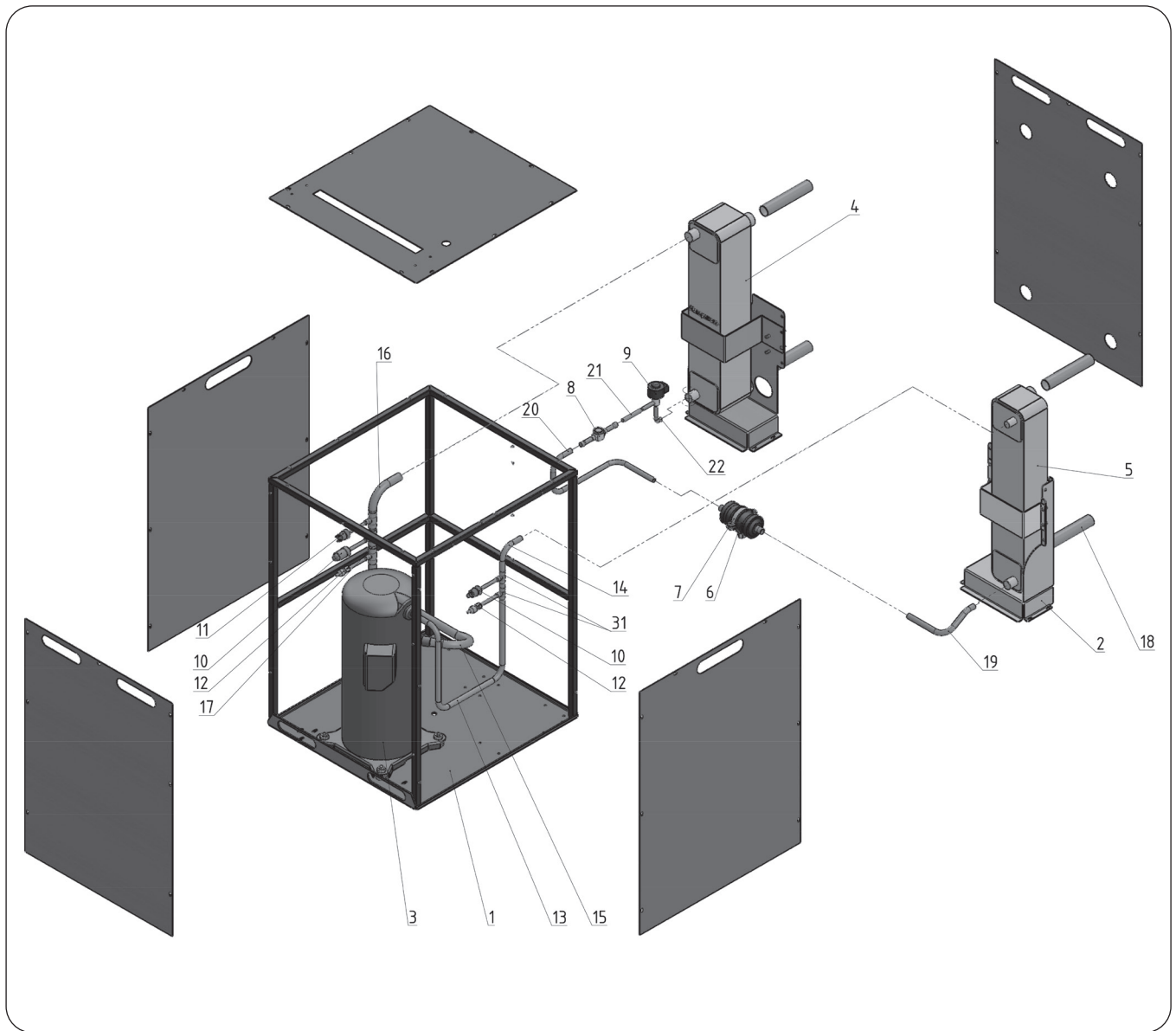

- | | |
|--------------------------------|--------------------------|
| 1 - Pallet and frame | 13 - D12-L720 Outlet 1 |
| 2 - Support for the evaporator | 14 - D12-L145 Outlet 1.1 |
| 3 - Compressor | 15 - D19-L530 Outlet 2 |
| 4 - BPHE evaporator | 16 - D19-L150 Outlet 2.1 |
| 5 - BPHE condenser | 17 - D19-L45 Outlet 2.2 |
| 6 - Filter dryer | 18 - D28-L150 Outlet 3 |
| 7 - Pipe clamp | 19 - D12-L235 Outlet 6 |
| 8 - Sight glass | 20 - D12-L480 Outlet 7 |
| 9 - Electric control valve | 21 - D12-L60 Outlet 8 |
| 10 - Pressure sensor | 22 - Double-pipe tap |
| 11 - Pressostat | 23 - Unequal tee |
| 12 - Schrader valve | |

8.2.2 Pinout of the controller board connectors

AI board

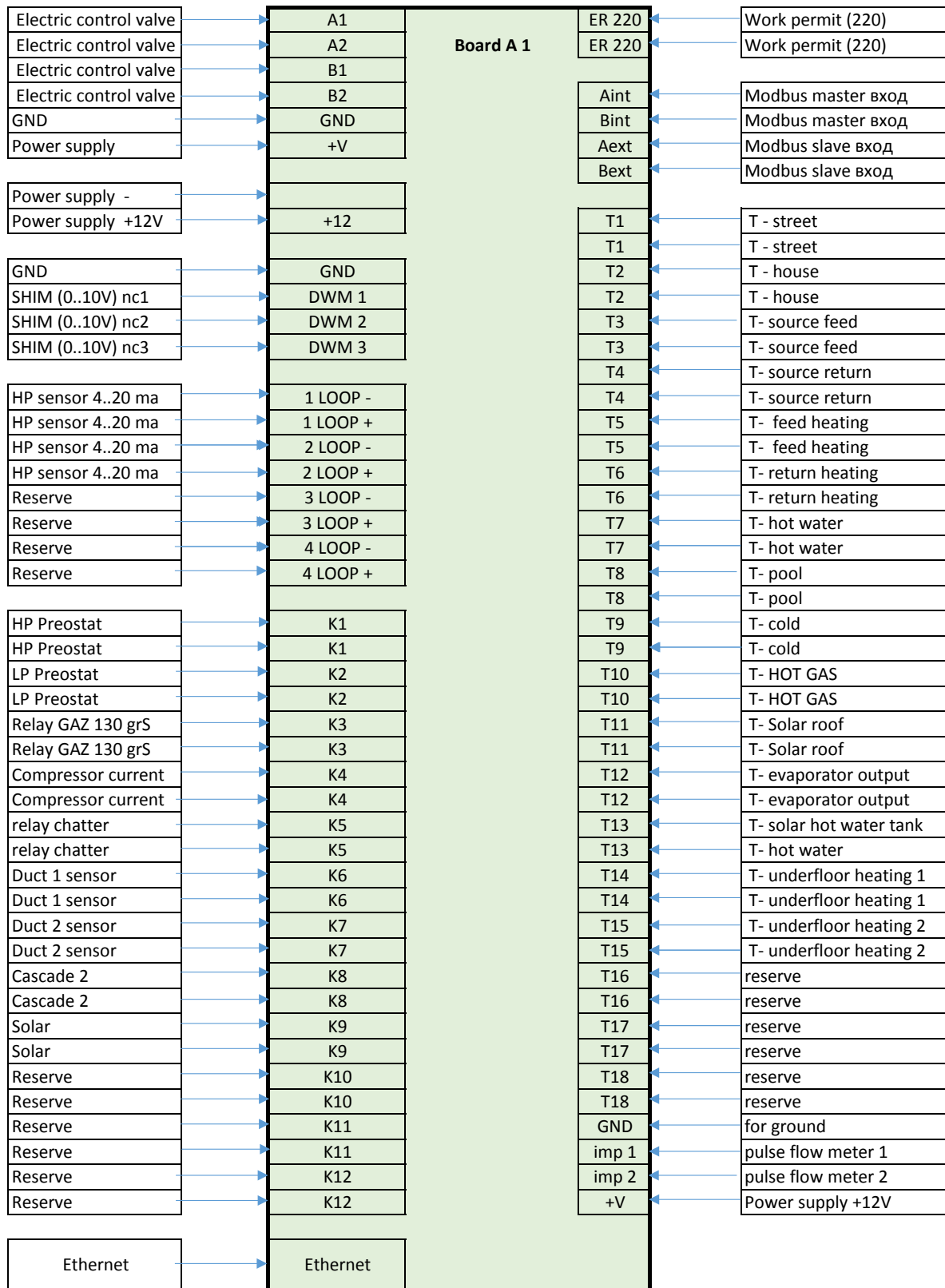

A2 board

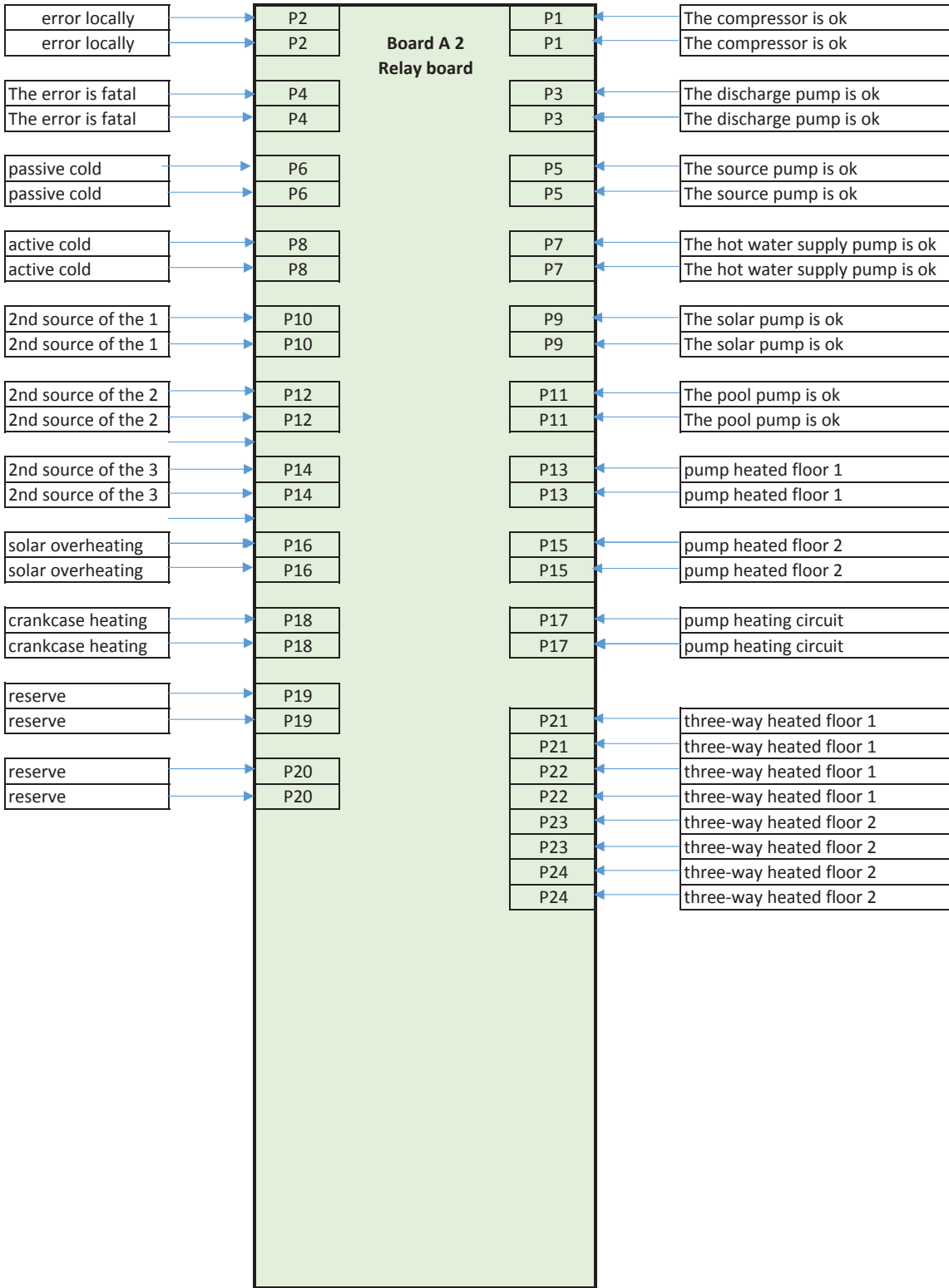

9. PREPARATORY ACTIVITIES

9.1 Общие сведения



INSTRUCTION

This heat pump is designed for indoor installation, except in humid areas.

The heat pump should not be installed under or next to the bedrooms. Pipe passages through walls and ceilings must be isolated from building noise.

The room in which the device is installed must meet the following requirements:

- ▶ Heated.
- ▶ Have a solid floor (the weight of the device is indicated in the technical specifications).
- ▶ Have a horizontal, level, and solid base to adjust the support legs of the heat pump.
- ▶ In order to ensure the quiet operation of the heat pump when it is installed on a seamless floor with an insulating base, an opening should be made in it along the edge of the connection to the installation site.
- ▶ The room must not be explosion-prone due to the presence of dust, gases, or vapors.
- ▶ The floor area in the installation room should be at least 3 m², while its volume should not be less than 6 m³.
- ▶ When you install the heat pump in the boiler room together with other heating devices, please make sure that this will not adversely affect the operation of other heating devices.

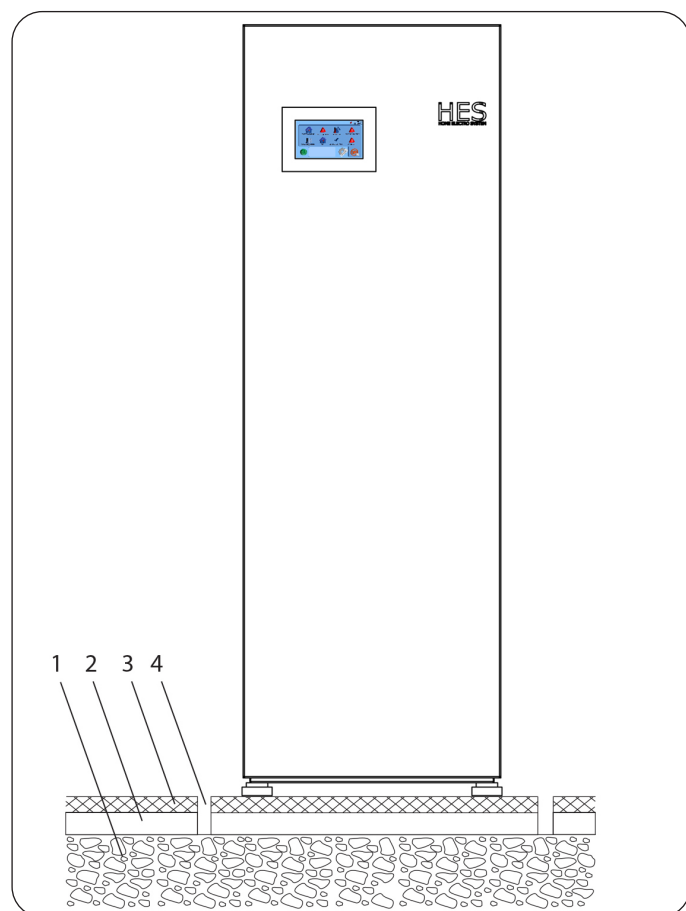

- 1** - Concrete floor
- 2** - Isolation from shock noise
- 3** - Seamless floor on an insulating base
- 4** - Opening

9.2 Electrical installation



WARNING: danger of electric shock

Any electrical connection and installation work must be carried out in accordance with national and regional regulations.



WARNING: danger of electric shock

The connection to the power supply must be permanent. The device must be disconnected from the mains with a solution of all contacts of at least 3 mm at all poles. The fulfillment of this requirement is ensured by contactors, linear circuit breakers, fuses, etc.



Damage to the device

The mains voltage must match the one indicated on the plate. The data on the nameplate should be observed.

Taking into account the fuses, please use a cable with a cross section:

Fuse	Cable cross
C 16 A	2,5 mm ²

The electrical characteristics are given in the «Parameter Table».



INSTRUCTION

Separate protective circuit breakers should be installed on the electrical circuits of the device and the control unit.

9.3 Intermediate storage

It is recommended to use a buffer accumulator to ensure the trouble-free operation of the heat pump.

The buffer storage is used not only for the hydraulic isolation of volumetric flows in the heat pump circuit and the heating circuit.

10. MOUNTING

10.1 Handling

- ▶ Transport the device in a package to protect it from damage.
- ▶ Protect the device from strong impacts during transportation.
- If the device is tilted during transportation, you can do this only for a short time on one of the sides.

The longer the device is in an inclined position, the more refrigerant oil is distributed in the system.

- Storage and transportation at temperatures below -20 °C and above are not allowed + 50 °C.



Damage to the device

The housing must be disconnected from the cooling unit plate and left standing on the floor!

10.2 Installation

- ▶ Remove the packaging film and upper and side shock-absorbing pads made of expanded polystyrene.
- ▶ Tilt the device slightly backward and remove it from the pallet.
- ▶ Place the device on a prepared base.
- ▶ Minimum intervals should be observed (see chapter «Connections and measures»).
- ▶ Unscrew the six screws on the front panel of the device



10.3 Dismantling of cladding parts

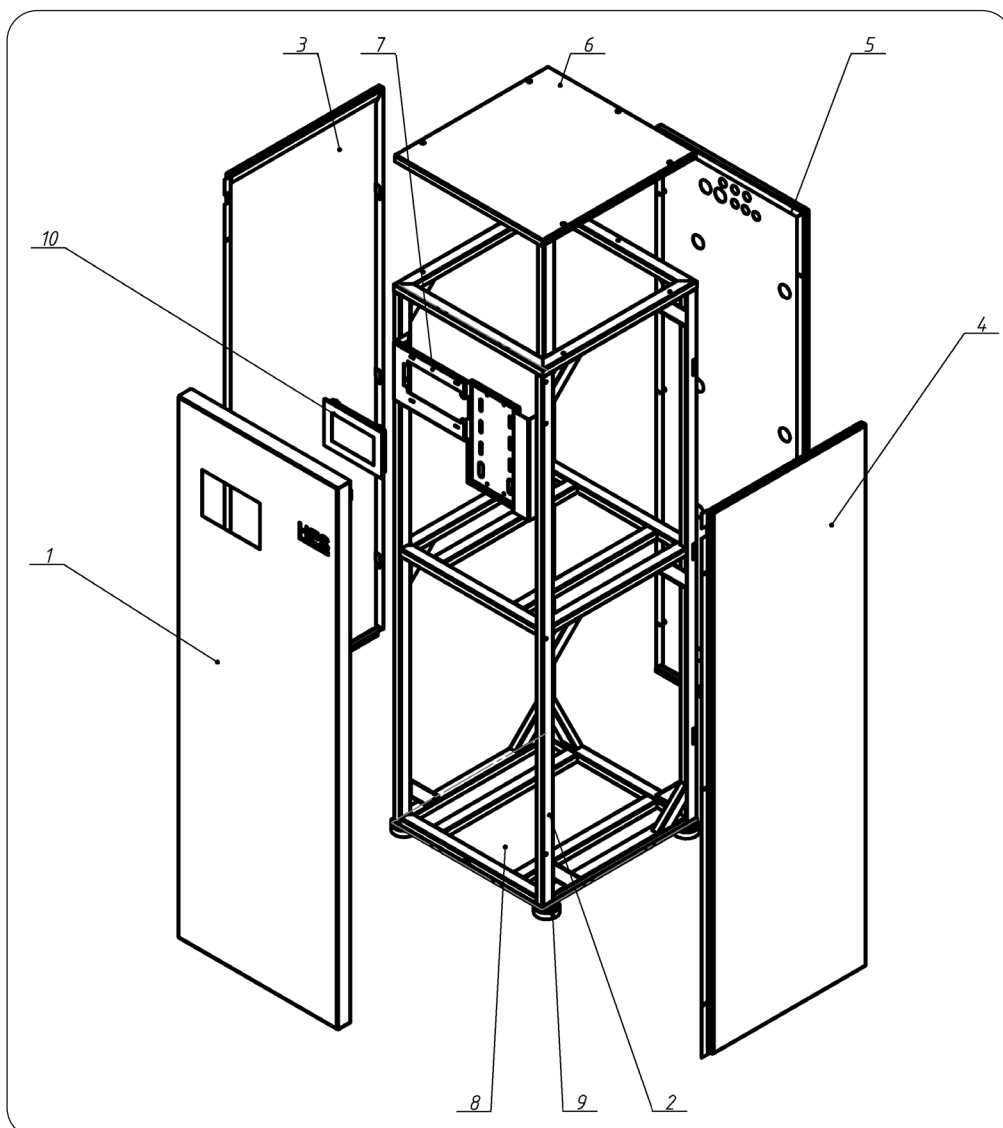

When removing the front jacket, care must be taken not to cut the tubes connecting the heat pump control system to the junction box. This also applies to the connection of the protective wiring which provides the electrical connection between the jacket and the housing.

- 1 - front panel
- 2 - HES frame
- 3 - left panel
- 4 - right panel
- 5 - back panel
- 6 - top panel
- 7 - display frame
- 8 - lower panel
- 9 - vibration support
- 10 - HES monitor

10.4 Installation of the heat source circuit (salt solution)

The external contour of the heat source (the brine contour) must be made in accordance with the design documentation.

10.4.1 Circulation pump and required volume flow

The circulation pump must comply with the operating conditions of the system, that is, take into account the nominal volume flow and pressure loss (see «Technical Properties»)

At any brine temperature, sufficient volumetric flow must be ensured, that is: the permissible deviation of the nominal volumetric flow rate at a brine temperature of 0 ° C is +10%.

10.4.2 Connection and filling with brine

Before connecting the heat pump, please check the tightness of the heat source circuit and thoroughly rinse it.

You need to determine the volume of the heat source circuit.

The total volume of the brine after its preparation from undiluted ethylene glycol and water should be checked for the chloride content in the water. This indicator should not exceed 300 ppm (parts per million).

The ratio of the mixture components

The concentration of brine varies when you use a geothermal collector or a geothermal probe as a heat source.

The ratio of the mixture components is indicated in the following table.

	Ethylene Glycol	Water
Geothermal probe	25 %	75 %
Geothermal collector	33 %	67 %

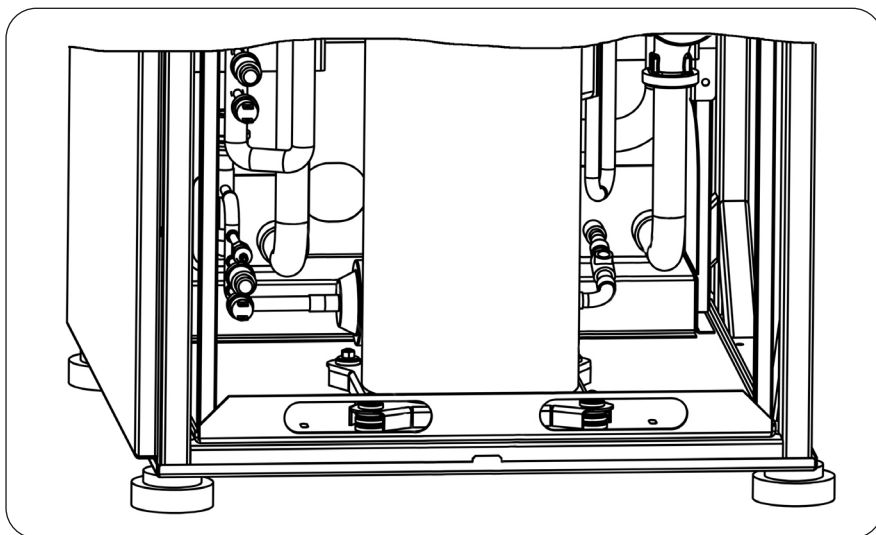

Checking the brine concentration:



INSTRUCTION

The length of the collector hose depends on the composition and water saturation of the rock/soil, the climatic zone, and the climate control system (radiators or floor heating system), as well as the heating requirements of the building. The size of each installation must be selected individually.

The maximum length of one branch for a collector should not exceed 400 m.

In cases when you need to have several collectors, they must be connected in parallel with the possibility of adjusting the flow of the corresponding branch.

To take the heat from the topsoil, the hose should be laid at a depth appropriate to local conditions, and the distance between the hoses should be at least 1 meter.

In the case of drilling several wells, the distance between them must correspond to local conditions.

You have to ensure uniform lifting of the manifold hose in the direction of the heat pump in order to avoid the formation of air pockets. If this is not possible, ventilation holes should be used.

Since the temperature in the brine system can drop below 0 °C, the system should be protected from freezing to a temperature of - 15 °C.

10.4.3 Control of the volumetric flow rate of the heat source

The volume flow rate in the heat source is set by the temperature difference in the circuit of the heat source.

Determine the temperature difference. To do this, turn on the device in heating or hot water preparation mode.

The maximum temperature difference of the heat source circuit.

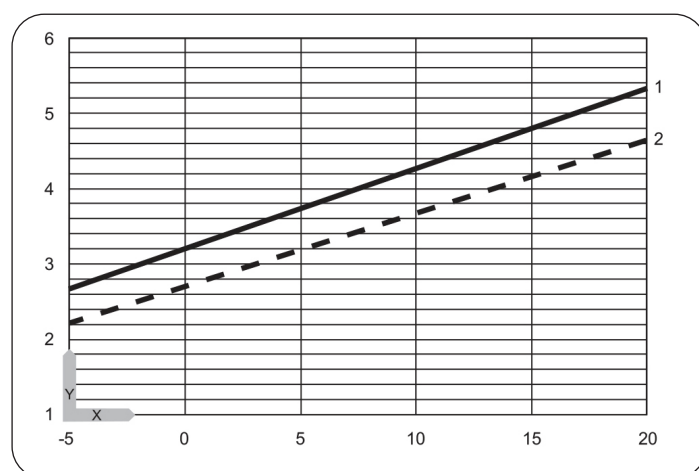

Y - is the max temperature difference [K]

X - is the temperature of the heat source at the inlet [°C]

1 - 35 °C heating system supply line

2 - 58 °C heating system supply line



INSTRUCTION

When you specify the source according to the device commissioning statement, set «Ethylene Glycol» on the HES controller, otherwise, the frost protection relay will turn off the heat pump at temperatures below 7 °C.



INSTRUCTION

The temperature of the heat source at the inlet can be read on the display of the heat pump control system in the Info Temperatures menu section.

10.5 Connection of heating circuits

The heating system with a heat pump must be performed by a specialist in accordance with the wiring diagram of the heating/water supply system contained in the design documentation.

► The piping system should be thoroughly rinsed before connecting the heat pump. Impurities such as welding grease, rust, sand, sealing material, etc. negatively affect the operational safety of the heat pump.

► Connect the heat pump from the heating system side. Keep an eye on the tightness.

You need to ensure that the supply line and the return line of the heating system are connected correctly.

Carry out thermal insulation measures in accordance with the applicable regulatory documents.

When you design the heating circuit, please observe the maximum achievable value of the external pressure difference.

10.5.1 Oxygen diffusion



Damage to the device

The use of open heating systems or steel pipes in combination with plastic pipe systems that are not protected from diffusion for floor heating should be avoided.

When you use floor heating systems made of plastic pipes that are not protected from diffusion, or open heating systems, an internal tank, metal radiators, or steel pipes can corrode due to the oxygen diffusion onto steel parts.

Corrosion products, such as rust deposits, can settle in the heat pump condenser and, as a result of the narrowing of the cross-section, cause a loss of heat pump power or shutdown due to the operation of a high-pressure switch.

10.5.2 The second external heat generator

In bivalent heating systems, the heat pump should always be connected to the main line of the second heat generator (for example, a liquid fuel boiler).

The high temperature of the mains water: In the bivalent mode, the reverse flow of water from the second heat generator can be passed through the heat pump directly after its shutdown, but at a maximum permissible temperature of 80 °C.

10.5.3 Water quality

Please observe the following when you fill the system with water for heating to minimize damage from the formation of lime deposits:

The total hardness of the water should be 1 °dH (0.18 mmol/L of alkaline areas).

If it is impossible to fulfill the above requirements, please take measures to soften the water.



Damage to the device

It is forbidden to use completely desalinated or rainwater as this leads to accelerated corrosion. You can buy appropriate equipment for softening water and filling/flushing heating systems in specialized stores.

10.5.3 Removing air from the heating system

► Carefully remove air from the piping system.

10.6 Electrical connection



INSTRUCTION

Follow the operating and installation instructions provided with the heat pump control module

Connection work can only be performed by a specialist with a permit and in accordance with this manual!

Please obtain technical specifications from the relevant electrical grid company for connecting the device.

► Follow the instructions in the «Preparatory work for electrical installation» chapter.



ПРЕДУПРЕЖДЕНИЕ: опасность поражения электрическим током
Please unplug the device before starting work on the junction box.



INSTRUCTION

The connection terminals are located in the junction box of the device.



INSTRUCTION

After connecting the device, the provisions of the «De-installation of cladding» chapter must be observed.

Cables that comply with the regulations must be used for connection.

- Open the hinged lid on the junction box. To do this, unscrew the mounting screws on the side, on top of the junction box.
- All connecting wires and sensor wires should be laid through the cable entries provided for this purpose from above in the rear wall (see Chapter «Connections and dimensions»).
- Run all wires through the discharge clamp.
- Connect the wires according to the illustrations below.
- Then check the action of the discharge clamps.



INSTRUCTION

When you close the device case, please follow the instructions in the «Installation of cladding» chapter.

Circulation pumps

The connection of the circulation pumps must be carried out in accordance with the requirements of the design documentation.



Damage to the device

If high-performance circulation pumps are used, they must be connected directly. To do this, an external relay with a breaking power of at least 10 A/250 V AC is required.

Modules

In the modular mode of operation, the connection of individual heat pumps is made through the bus terminal 1,2,3.

It is necessary to make sure that the High, Low and Ground busbars are connected correctly both in the HES heat pump control device and in the heat pump.

10.7 Installation of cladding elements

When you install the cladding, the following instructions must be observed:

- ▶ Close the hinged cover on the junction box.
- ▶ Fix the hinged lid by tightly tightening the mounting screws with toothed elastic washers.
- ▶ Install the cover on the device.
- ▶ After installing the front jacket, please secure it with screws through the side walls as shown in the figure. When installing the front jacket, the linings must be installed using the appropriate screws and toothed elastic washers. Pads, screws, and toothed elastic washers are included in a separate package.
- ▶ When you install the front jacket, the prescribed method of connecting the protective wire must be followed.

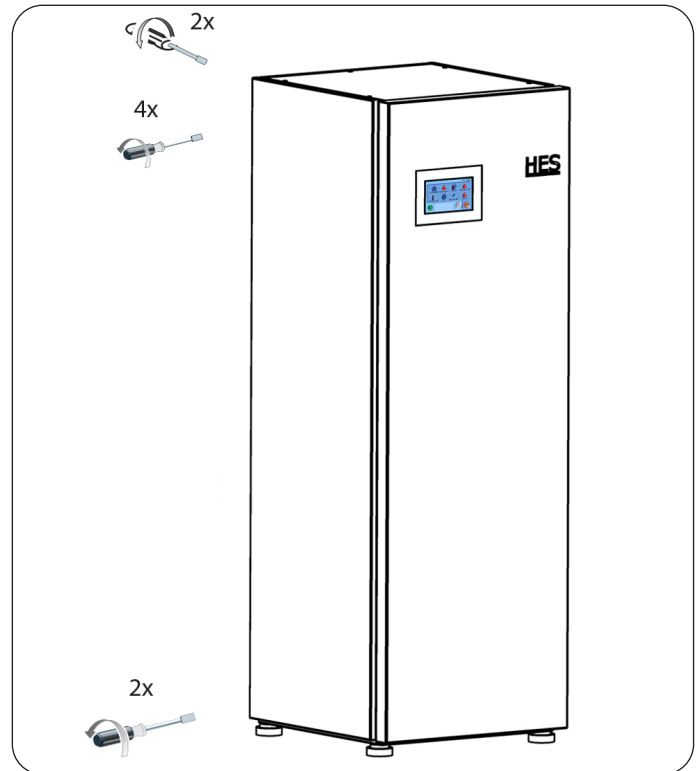

11. START-UP

Commissioning of the device, all settings of the thermal pump control device at the commissioning level, as well as teaching the user to operate it, must be carried out by a specialist.

Commissioning must be carried out according to the instructions of this technical data sheet, the heat pump control device operation and installation manual, and the heat pump operation and installation manual.

You can invite our service specialists for commissioning (this service is fee-based).

If this device is used in production, it please take into account the safety regulations provided for during commissioning. Detailed information on this issue can be obtained from the relevant supervisory authority (for example, technical supervision).

After commissioning, please complete the commissioning protocol provided in this manual.

11.1 Monitoring before commissioning of the heat pump control device



Damage to the device

If there is a heated floor heating system, the maximum temperature of the system should be taken into account.

- ▶ Check for the required pressure in the heating system and whether the quick air removal valve is open.

- ▶ Check the correct location and connection of the external sensor and the return line sensor.
- ▶ Check the correct network connections.
- ▶ Check the correct connection of the heat pump connection wire (bus wire).

11.2 Commissioning of the heat pump control device

The commissioning of the heat pump control device and all settings must be carried out according to the operation and installation manual of the heat pump control device.

11.3 Setting up the graphical heating characteristics during initial commissioning

The efficiency of the heat pump decreases as the temperature in the supply line is rising. Therefore, you need to carefully adjust the graphic characteristics of the heating. Overly tuned heating schedules cause the zone or temperature control valves to close, which causes the volume flow to drop below the minimum in the heating circuit.

The graphical characteristics of the heating can be adjusted correctly in the following ways:

- Fully open the temperature control valve(s) or the zone valve(s) in the master room (for example, in the living room and bathroom). We do not recommend installing temperature control or zone valves in the main room. The temperature for these rooms should be adjusted using a remote control.
- Coordinate the graphic characteristics of heating at different outdoor temperatures (for example – 10 °C and 10 °C) so that the desired temperature is set in the main room.

Approximate values for the initial stage:

Parameter	Heated floor	Radiator heating
Heating schedule	0,4	0,8
The dynamics of the regulator	5	15
Room temperature	20°C	20°C

If the room temperature during the transition period (outdoor temperature of about 10 °C) is too low, please increase the «room temp» parameter (Indoor temperature).



INSTRUCTION

If the remote control is not installed, increasing the «room temp» parameter (Room temperature) leads to a parallel shift in the heating schedule.

If the room temperature is very low at low outdoor temperatures, please increase the «Heating curve» parameter (Graphical heating characteristic).

After increasing the «Heating curve» parameter (Graphical heating characteristic) and at higher outdoor temperatures, the zone or thermostatic control valve in the master compartment must be set to the desired temperature.



INSTRUCTION

Lower the temperature in the entire building using temperature reduction programs rather than by shutting off all central or temperature control valves.

11.4 Device transfer

Explain the principle of the device operation to the user and familiarize him with the rules of the device use.



INSTRUCTION

This operating and installation manual should be handed over to the user for careful storage. Any instructions in this manual must be carefully followed. They contain important information on safety, operation, installation and maintenance of the device.

11.5 Control and operation



Damage to the device

The power supply must not be interrupted even after the end of the heating season. When the power supply is turned off, the active protection of the system from freezing is not guaranteed.

You do not need to turn off the system in summer. The control system of the heat pump automatically switches from winter to summer time.

12. DECOMMISSIONING

If installation decommissioning is required, the heat pump control system should be put into standby mode. At the same time, the functions of ensuring safety and protection against defrosting remain active.



Damage to the device

When the heat pump is completely turned off and there is a risk of frost, you need to drain the water from the system.

13. MAINTENANCE AND CLEANING

If there is a built-in heat meter, you need to regularly clean the sieves, even if they are slightly clogged.

In case of failures in the operation mode of the heat pump (for example, when the VD control relay is triggered) caused by deposits of corrosion products (rust plaque) in the condenser, their removal by chemical means using special solvents can only be performed by the service department.

14. TROUBLESHOOTING



INSTRUCTION

You need to comply with the requirements of the operating and installation instructions supplied with the heat pump control device.



INSTRUCTION

Only a qualified specialist has the right to perform control according to the following instructions.

If the malfunction is not detected using the heat pump control device, control of the elements on the integrated IHPC heat pump control should be performed.

- ▶ Open the junction box.
- ▶ To fix the problem, read the following sections and follow the instructions.

14.1 Elements on the IHPC module

IHPC (Integrated Heat Pump Control) provides assistance in detecting faults that have not been identified by the HES heat pump control device.

14.1.1 LEDs - «optional» - not available on all models.

The fault	Cause	Remedy
The device turns off and it turns on again after the idle time has elapsed. The yellow LED is glowing.	The malfunction of the heat pump was detected.	Check the failure message on the HES heat pump control device. To solve the problem, use the manual of the heat pump control device (list of faults). Reset the integrated control of the heat pump (see the HES controller manual).
The device turns off completely. The red LED lights up.	Three malfunctions were detected during an hour and a half of the system operation.	Check the failure message on the HES heat pump control device. To solve the problem, use the manual of the heat pump control device (list of faults). Reset the integrated control of the heat pump (see the HES controller manual).

14.1.2 Reset and restart

A complete error reset, a fatal error reset, or a rollback to factory settings is performed through the service settings menu.

15. TECHNICAL SPECIFICATIONS

15.1 Connections and sizes on HES ECO-G20 and HES ECO-G27 models

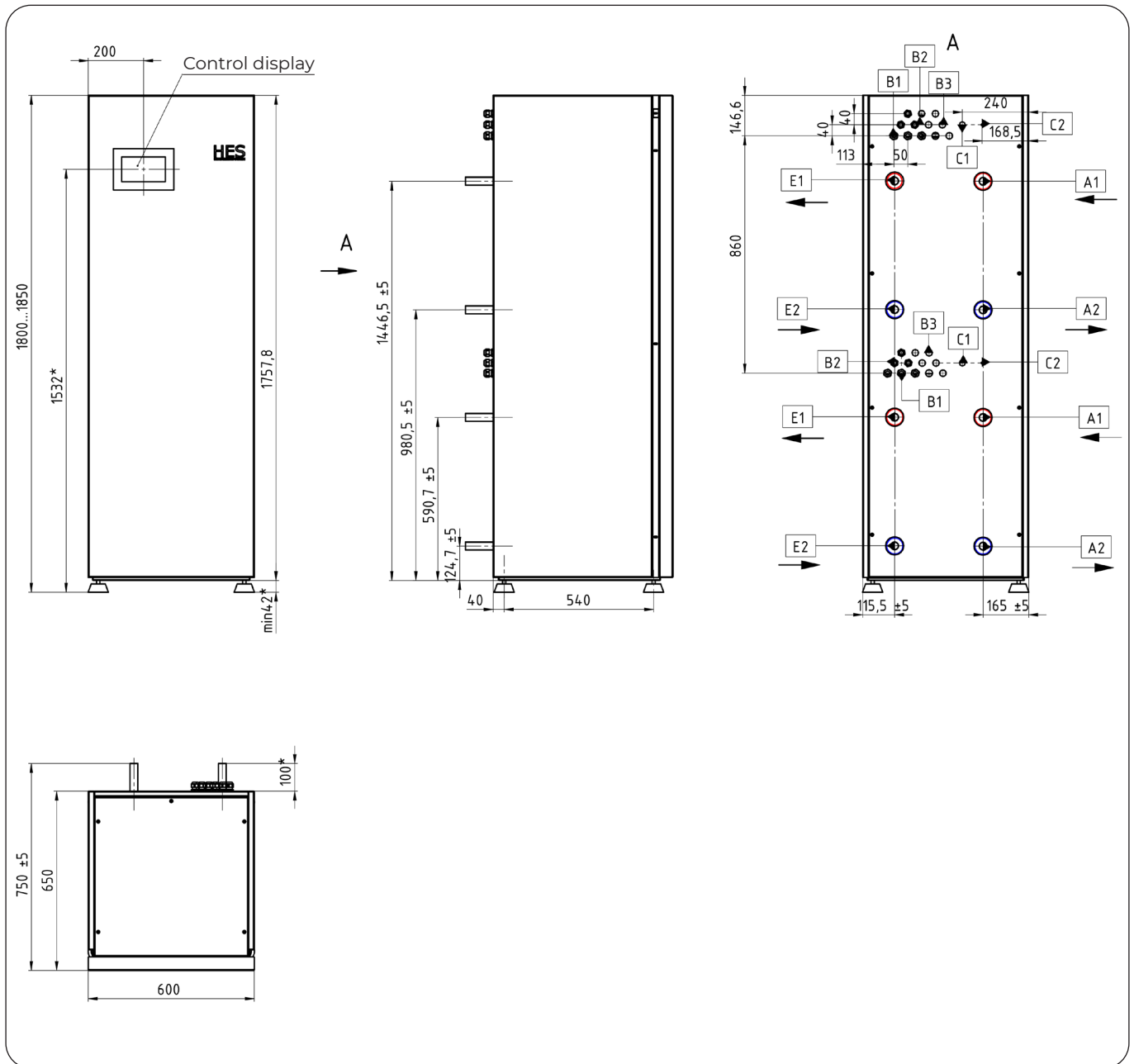

Legend:

Source of heat

A1 - feed line;
A2 - return line.

Heating

E1 is the feed line;
E2 is the return line.

Electrical Connection

B1 - wiring input;
B2 - electric cable inlet;
B3 - safety kit;
C1 - internet connector;
C2 - antenna connector.

* - dimensions for reference

15.2 Connections and sizes on HES ECO-G40, HES ECO-G52, HES ECO-G66 models

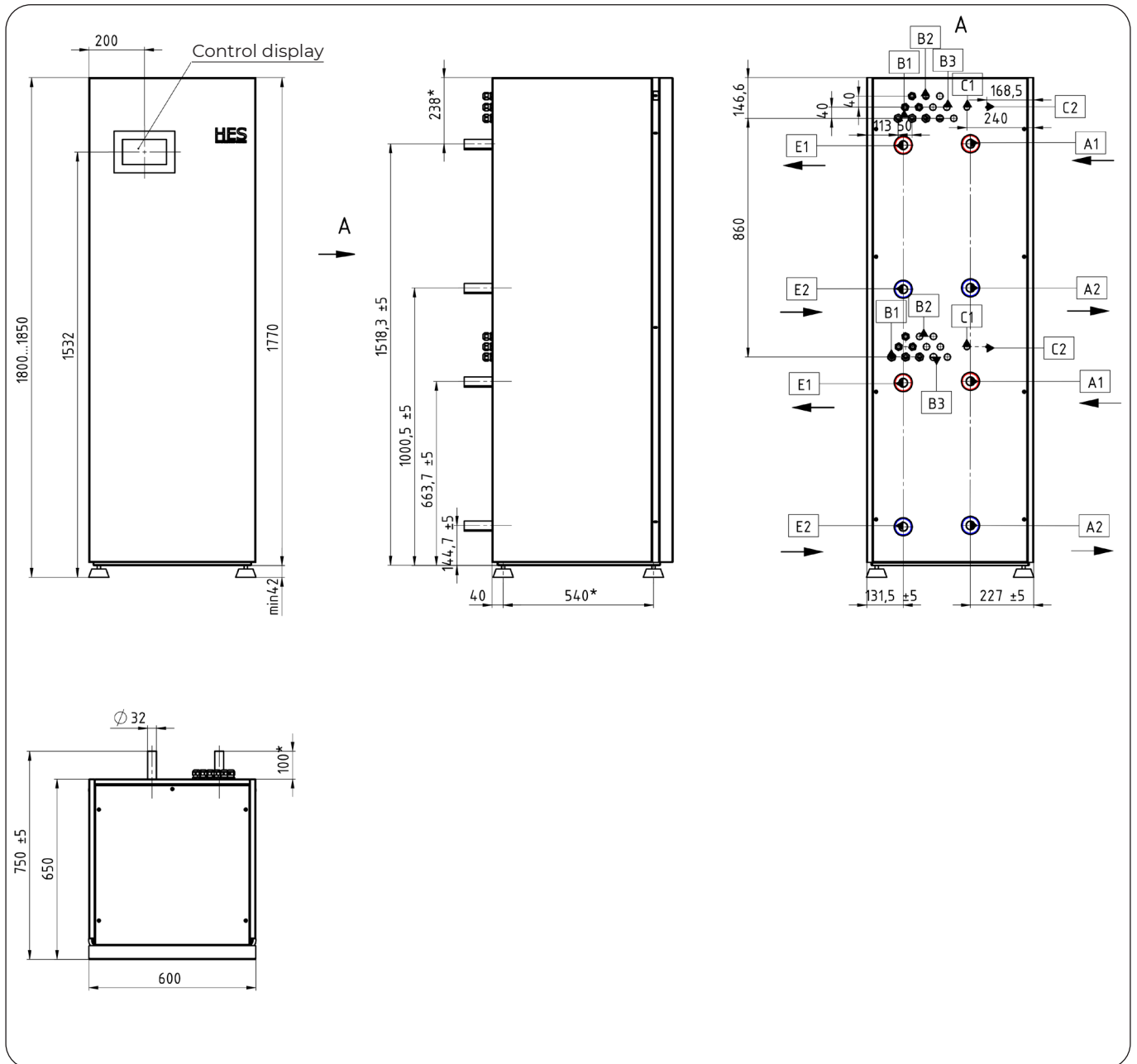

Legend:

Source of heat

A1 - feed line;
A2 - return line.

Heating

E1 is the feed line;
E2 is the return line.

Electrical Connection

B1 - wiring input;
B2 - electric cable inlet;
B3 - safety kit;
C1 - internet connector;
C2 - antenna connector.

* - dimensions for reference

15.3 Electrical circuits

Electrical connection. Part 1.

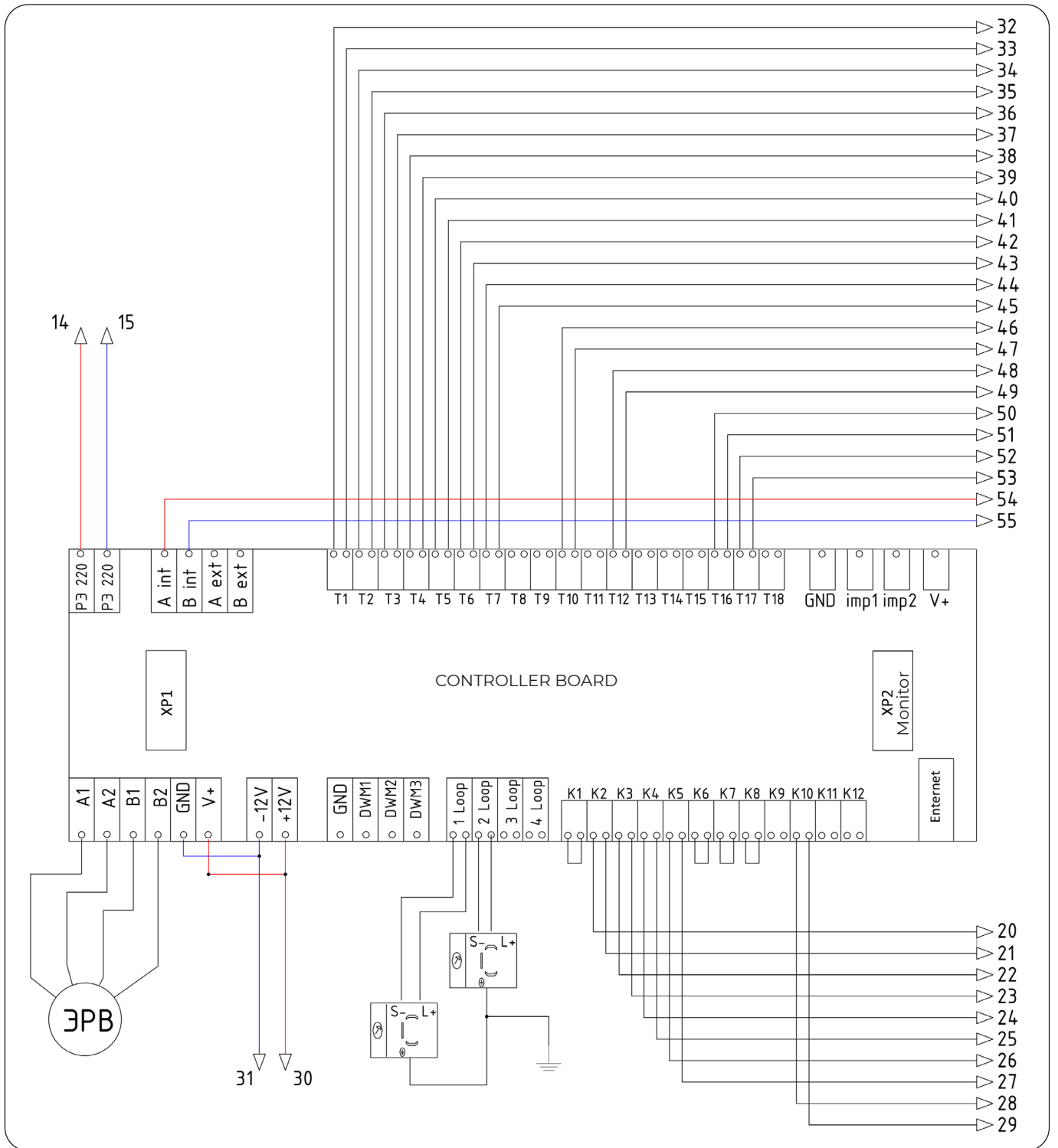

Legend

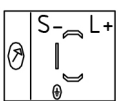

-- pressure sensor;

⏏ - grounding

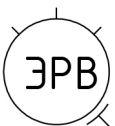

- electronic expansion valve;

Legend**CONTROLLER BOARD**

K1 - HP pressostat	T11 - Solar temperature (roof)
K2 - LP pressostat	T12 - Evaporator temperature (outlet)
K3 - relay gas 130 C	T13 - Solar temperature HWS tank
K4 - compressor current	T14 - Floor heating temperature 1
K5 - relay chatter	T15 - Floor heating temperature 2
K6 - D. duct 1	T16 - Heating temperature
K7 - D. duct 2	T17 - Boiler temperature
K8 - cascade 2	T18 - standby temperature
K9 - Solar	GND - ground;
K10 - phase relay	imp1 - pulse flow meter 1
K11 - standby	imp2 - pulse flow meter 2
K12 - standby	V+ - 12V power supply
Enetnet - the Internet	A1 - ERV
RE 220 - Operation resolution (220V)	A2 - ERV
Aint - Modbus master (input)	B1 - ERV
Bint - Modbus master (input)	B2 - ERV
Aext - Modbus slave (output)	GND- ground
Bext - Modbus slave (output)	V+ - power supply+ 12V
T1- Street temperature	-12V - supply -
T2 - indoor temperature	+12V - supply + 12V
T3 - Source temperature (supply)	GND - ground
T4 - Source temperature (return)	DWM1 - SHIM (0..10V) nc1
T5 - Heating temperature (supply)	DWM2 - SHIM (0..10V) nc2
T6 - Heating temperature (return)	DWM3 - SHIM (0..10V) nc3
T7 - HWS temperature	1 Loop - Sensor HP 4..20mA
T8 - Pool temperature	2 Loop - Sensor LP 4..20mA
T9 - Cold temperature	3 Loop - standby
T10 - HOT-gas temperature	4 Loop - standby

Electrical connection. Part 2.

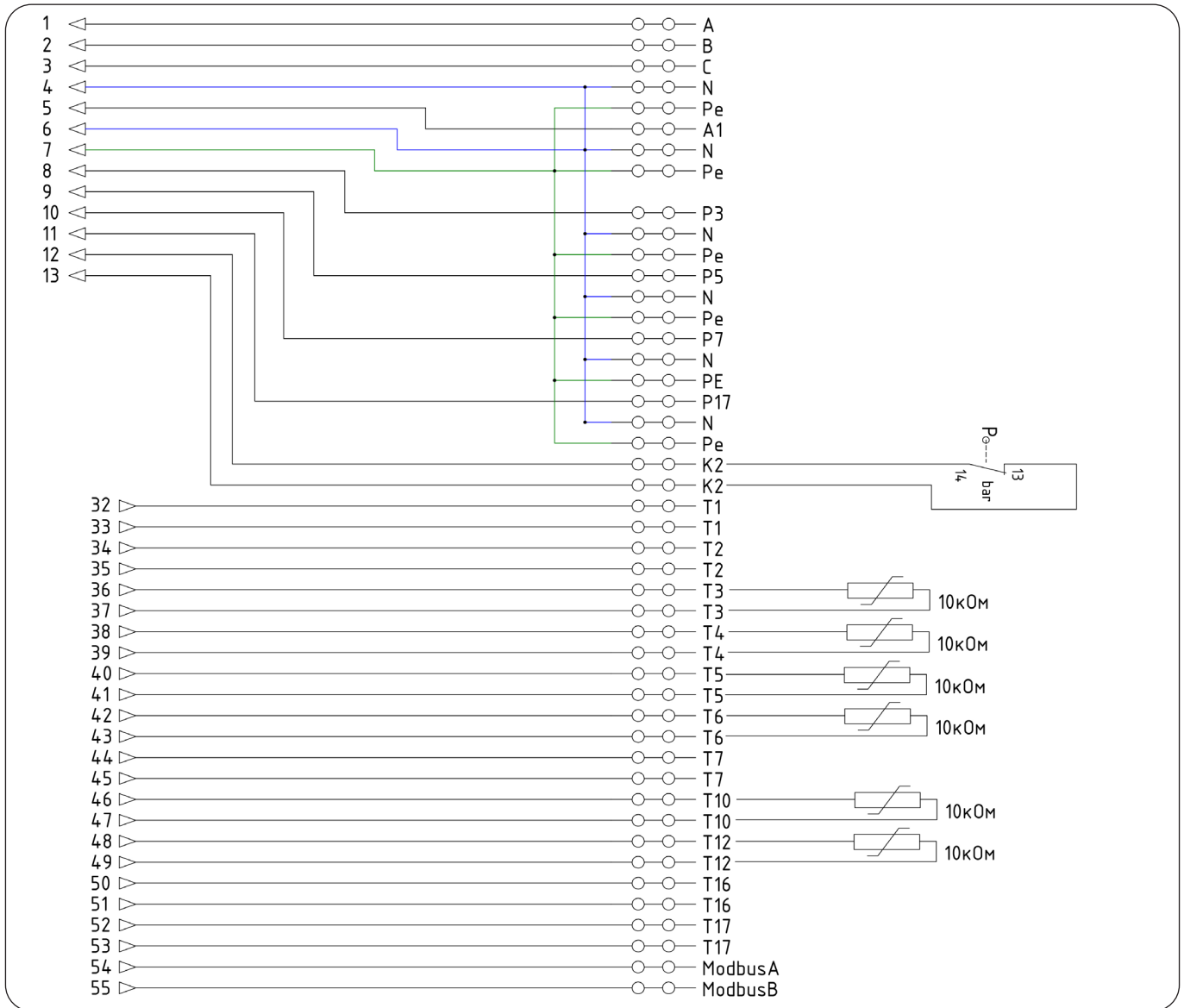
Legend

- temperature sensor;

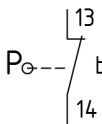

- pressostat.

A,B,C - compressor power supply phase (power part);

Pe - grounding;

A1 - control phase;

N - zero

RELAY BOARD

P1 - compressor

P3 - discharge pump

P5 - source pump

P7 - HWS pump

P17 - heating circuit pump

CONTROLLER BOARD

K2 - LP pressostat

T1 - Outdoor temperature

T2 - Indoor temperature

T3 - Source temperature (supply)

T4 - Source temperature (return)

T5 - Heating temperature (supply)

T6 - Heating temperature (return)

T7 - HWS temperature

T10 - HOT-gas temperature

T12 - Evaporator temperature (output)

T16 - Heating temperature

T17 - Boiler temperature

Aext - Modbus slave (output)



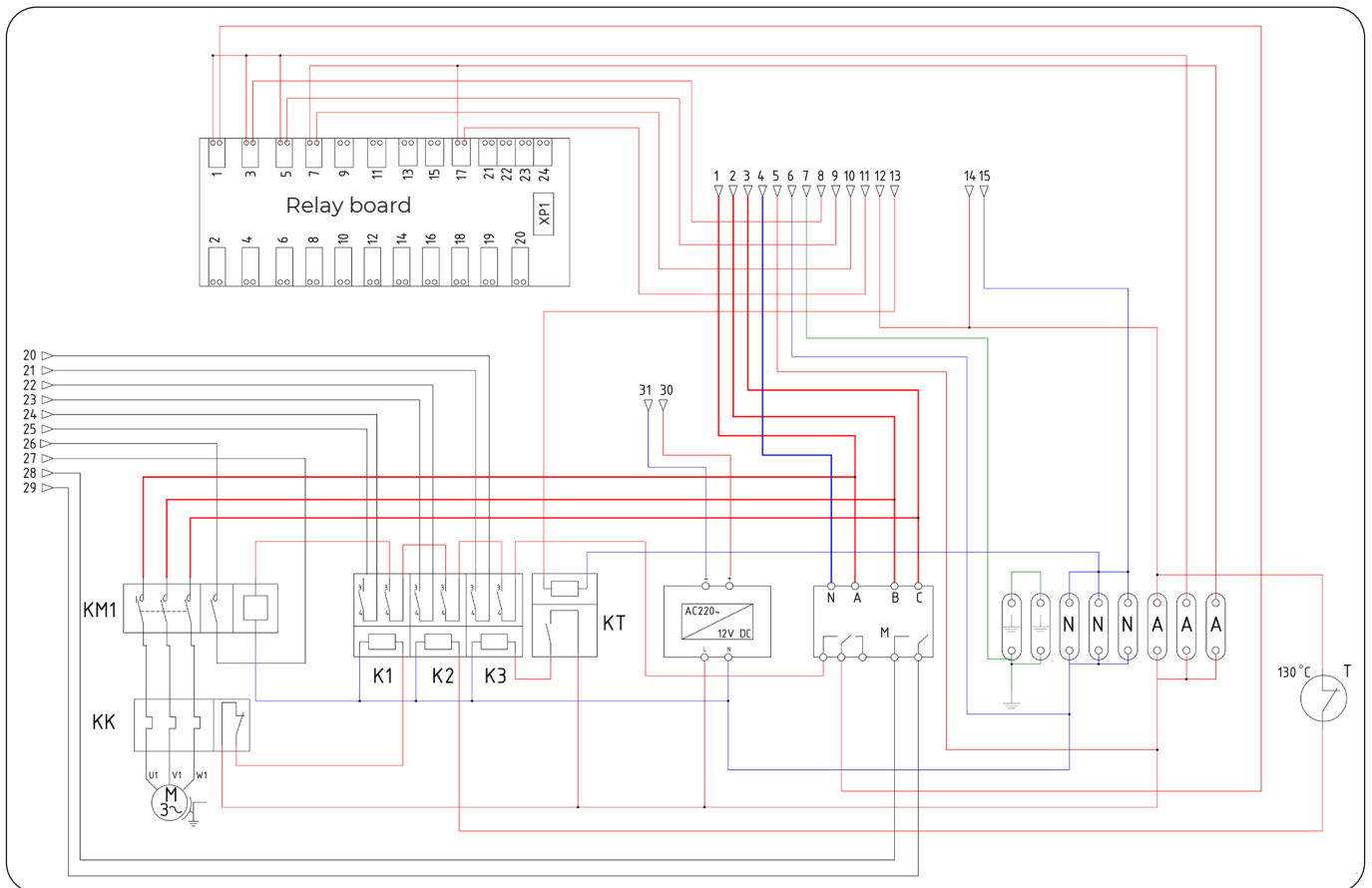

Bext - Modbus slave (output)

Aint - Modbus master (input)

Electrical connection. Part 3.

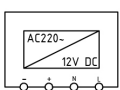
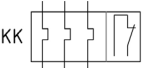
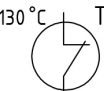
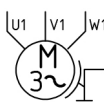

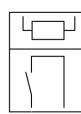
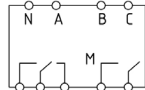
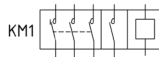
Legend

-  - terminal pad;
-  - power supply unit;
-  - thermal relay;
-  - thermo contactor;
-  - compressor;
-  - intermediate relay 230VAC;
-  - time delay relay;
-  - phase control relay;
-  - contactor;
- A,B,C - compressor power supply phase (power part);
- A1 - control phase;
- N - null;
-  - grounding.

RELAY BOARD

- 1. Compressor
- 2. Error (local)
- 3. Discharge pump
- 4. Error
- 5. Pump source
- 6. Passive cold
- 7. HWS pump
- 8. Active cold
- 9. Solar pump
- 10. 2nd power supply 1st.
- 11. Pool pump
- 12. 2nd power supply 2st.
- 13. Underfloor heating pump 1
- 14. 2nd power supply 3st.
- 15. Underfloor heating pump 2
- 16. Solar overheating
- 17. Heating circuit pump
- 18. Crankcase heating
- 19. Reserve
- 20. Reserve
- 21. Three-way valve heated floor 1
- 22. Three-way valve heated floor 1
- 23. Three-way valve heated floor 2
- 24. Three-way valve heated floor 2

Electrical power circuit. General.

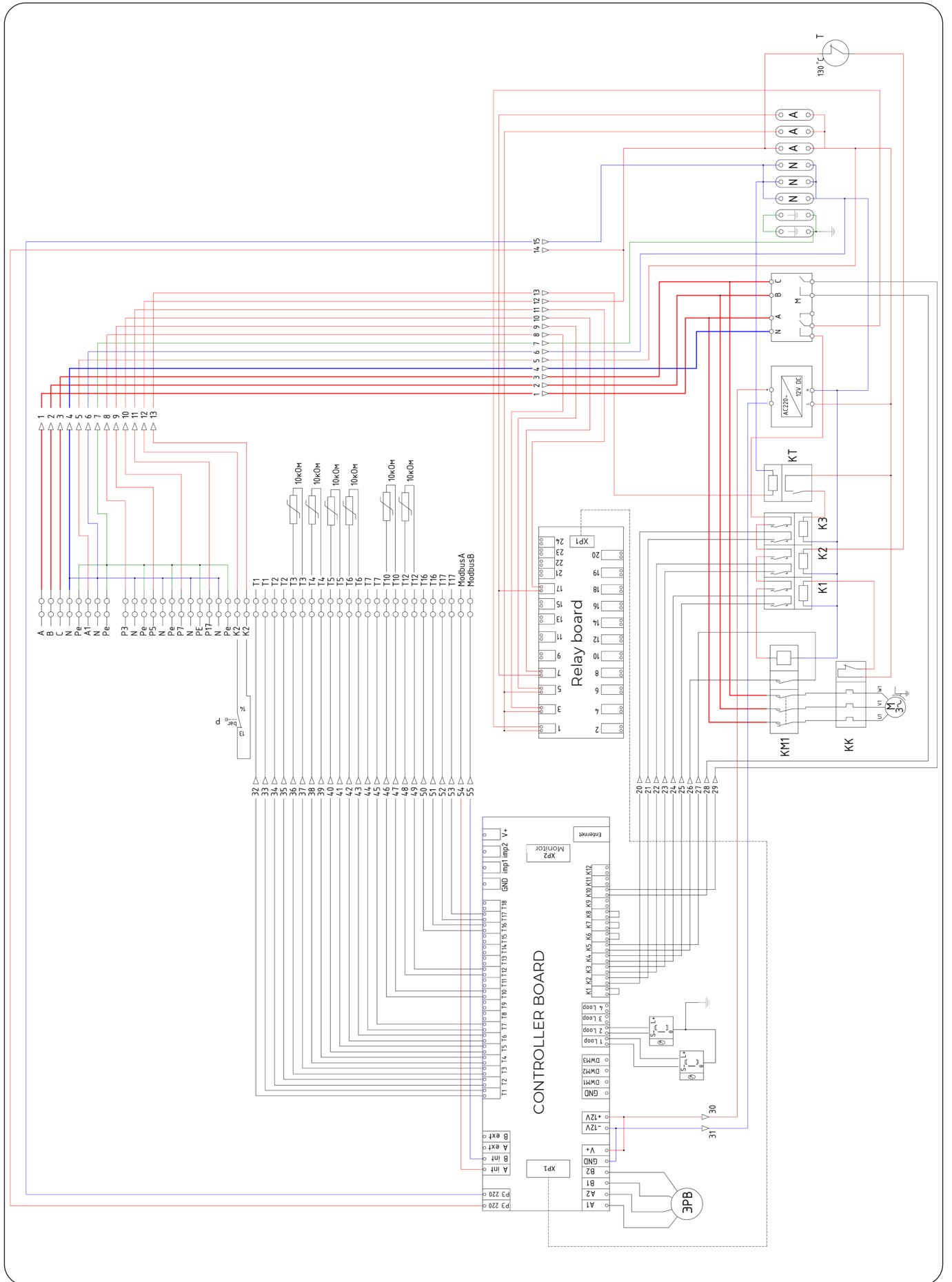

Legend

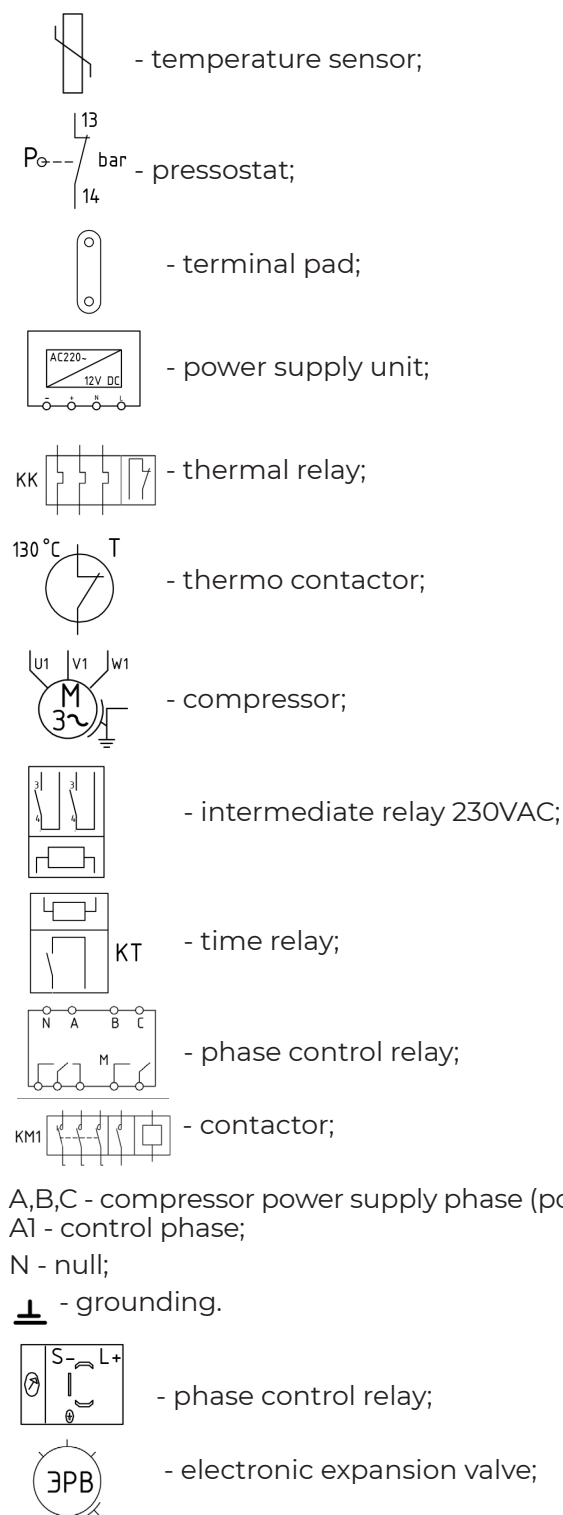

RELAY BOARD

1. Compressor
2. Error (local)
3. Discharge pump
4. Error
5. Pump source
6. Passive cold
7. HWS pump
8. Active cold
9. Solar pump
10. 2nd power supply 1st.
11. Pool pump
12. 2nd power supply 2st.
13. Underfloor heating pump 1

14. 2nd power supply 3st.
15. Underfloor heating pump 2
16. Solar overheating
17. Heating circuit pump
18. Crankcase heating
19. Reserve
20. Reserve
21. Three-way valve heated floor 1
22. Three-way valve heated floor 1
23. Three-way valve heated floor 2
24. Three-way valve heated floor 2

CONTROLLER BOARD

- K1 - HP pressostat
- K2 - LP pressostat
- K3 - relay gas 130 C
- K4 - compressor current
- K5 - relay chatter
- K6 - D. duct 1
- K7 - D. duct 2
- K8 - cascade 2
- K9 - Solar
- K10 - phase relay
- K11 - standby
- K12 - standby
- Internet - the Internet
- RE 220 - Operation resolution (220V)
- Aint - Modbus master (input)
- Bint - Modbus master (input)
- Aext - Modbus slave (output)
- Bext - Modbus slave (output)
- T1 - Street temperature
- T2 - indoor temperature
- T3 - Source temperature (supply)
- T4 - Source temperature (return)
- T5 - Heating temperature (supply)
- T6 - Heating temperature (return)
- T7 - HWS temperature
- T8 - Pool temperature
- T9 - Cold temperature
- T10 - HOT-gas temperature
- T11 - Solar temperature (roof)
- T12 - Evaporator temperature (outlet)
- T13 - Solar temperature HWS tank
- T14 - Floor heating temperature 1
- T15 - Floor heating temperature 2
- T16 - Heating temperature
- T17 - Boiler temperature
- T18 - standby temperature
- GND - ground;
- imp1 - pulse flow meter 1
- imp2 - pulse flow meter 2
- V+ - 12V power supply
- A1 - ERV
- A2 - ERV
- B1 - ERV
- B2 - ERV
- GND- ground
- V+ - power supply+ 12V
- 12V - supply -
- +12V - supply + 12V
- GND - ground
- DWM1 - SHIM (0..10V) nc1
- DWM2 - SHIM (0..10V) nc2
- DWM3 - SHIM (0..10V) nc3
- 1 Loop - Sensor HP 4..20mA
- 2 Loop - Sensor LP 4..20mA
- 3 Loop - standby
- 4 Loop - standby

Connection of the electrical part.

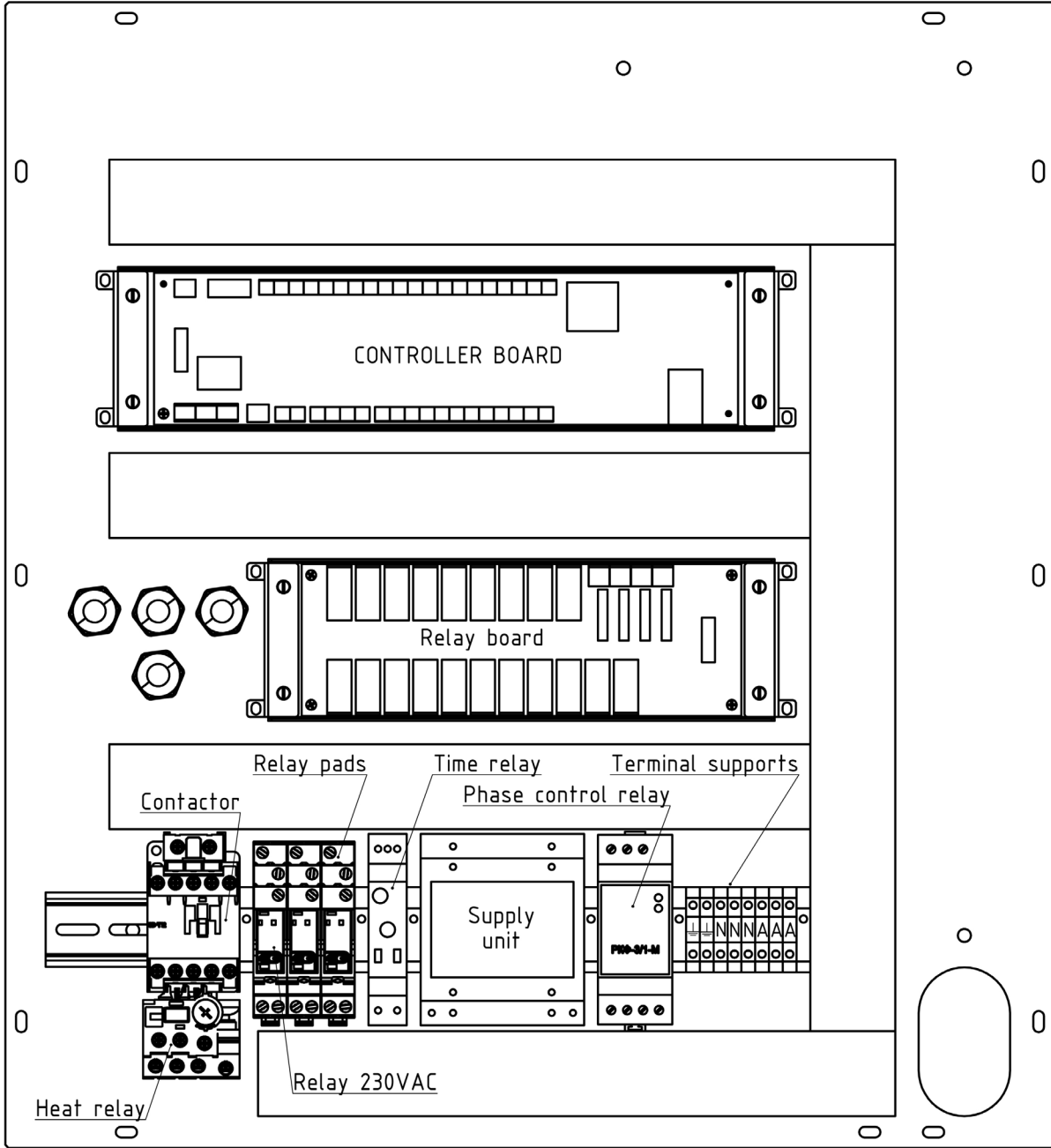

Legend

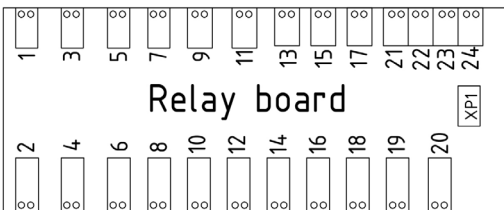

RELAY BOARD

- | | |
|--|---|
| <ul style="list-style-type: none"> 1. Compressor 2. Error (local) 3. Discharge pump 4. Error 5. Pump source 6. Passive cold 7. HWS pump 8. Active cold | <ul style="list-style-type: none"> 9. Solar pump 10. 2nd power supply 1st. 11. Pool pump 12. 2nd power supply 2st. 13. Underfloor heating pump 1 14. 2nd power supply 3st. 15. Underfloor heating pump 2 16. Solar overheating 17. Heating circuit pump 18. Crankcase heating 19. Reserve 20. Reserve 21. Three-way valve heated floor 1 22. Three-way valve heated floor 1 23. Three-way valve heated floor 2 24. Three-way valve heated floor 2 |
|--|---|

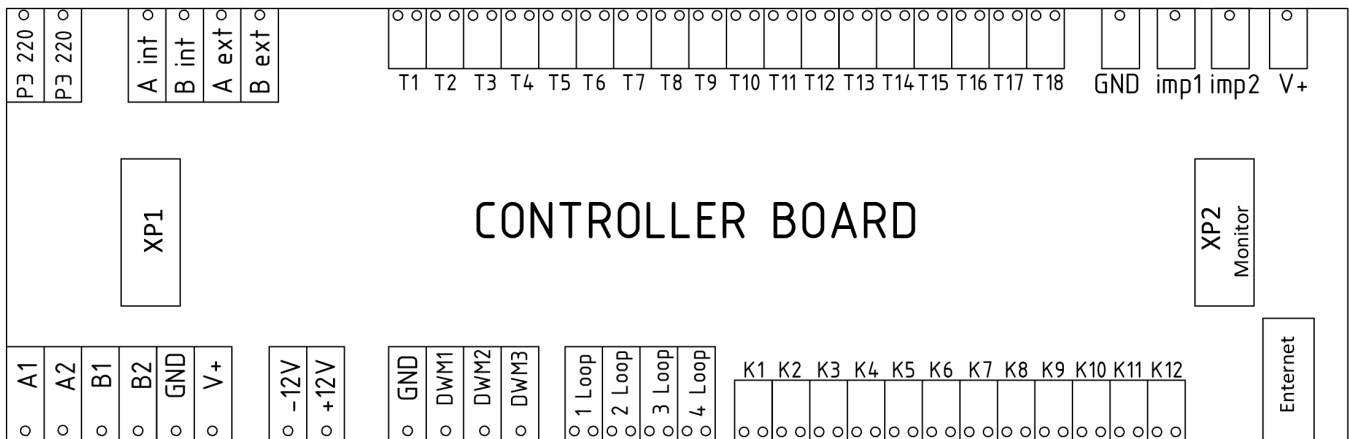

CONTROLLER BOARD

RE 220 - Operation resolution (220V)

Aint - Modbus master (input)

Bint - Modbus master (input)

Aext - Modbus slave (output)

Bext - Modbus slave (output)

T1 - Street temperature

T2 - indoor temperature

T3 - Source temperature (supply)

T4 - Source temperature (return)

T5 - Heating temperature (supply)

T6 - Heating temperature (return)

T7 - HWS temperature

T8 - Pool temperature

T9 - Cold temperature

T10 - HOT-gas temperature

T11 - Solar temperature (roof)

T12 - Evaporator temperature (outlet)

T13 - Solar temperature HWS tank

T14 - Floor heating temperature 1

T15 - Floor heating temperature 2

T16 - Standby temperature

T17 - Standby temperature

T18 - Standby temperature

GND - ground;

imp1 - pulse flow meter 1

imp2- pulse flow meter 2

V+ - 12V power supply

K1 - HP pressostat

K2 - LP pressostat

K3 - relay gas 130 C

K4 - compressor current

K5 - relay chatter

K6 - D. duct 1

K7 - D. duct 2

K8 - cascade 2

K9 - Solar

K10 - standby

K11 - standby

K12 - standby

Eneternet - the Internet

A1 - ERV

A2 - ERV

B1 - ERV

B2 - ERV

GND- ground

V+ - power supply+ 12V

-12V - supply -

+12V - supply + 12B

GND - ground

DWM1 - SHIM (0..10V) nc1

DWM2 - SHIM (0..10V) nc2

DWM3- SHIM (0..10V) nc3

1 Loop - Sensor HP 4..20mA

2 Loop - Sensor LP 4..20mA

3 Loop - standby

4 Loop - standby

A - compressor power supply phase (power part);

N - null.

⏏ - grounding

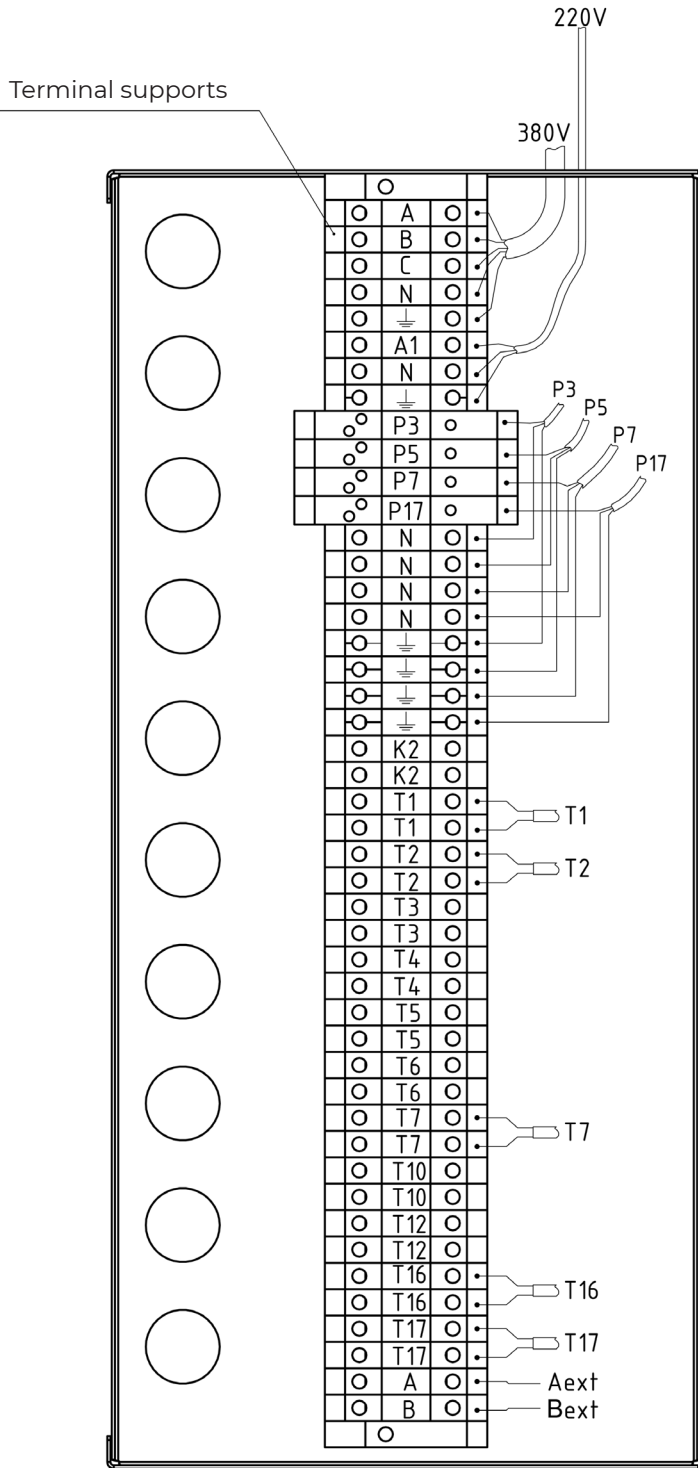

Legend

380V - Connection to mains 380V

220V - Connection to mains 220V

T1 - Outdoor temperature

T2 - Indoor temperature

T7 - HWS temperature

T10 - HOT-gas temperature

T16 - Heating temperature

T17 - Boiler temperature

P3 - discharge pump

P5 - source pump

P7 - HWS pump

P17 - heating circuit pump

A,B,C - supply phase

A1 - control phase;

N - zero;

\perp - grounding;

Aext - Modbus slave

Bext - Modbus slave

15.4 HES ECO-G 20 Power Diagram

Notation to the power diagram

Y Heating capacity [kW] / Power consumption [kW] / Power factor e [-]

X Inlet medium temperature WQA [°C]

1 Supply line temperature 35 °C, full load

2 Supply line temperature 50 °C, full load

3 Supply line temperature 58 °C, full load

Heating capacity HES ECO-G 20

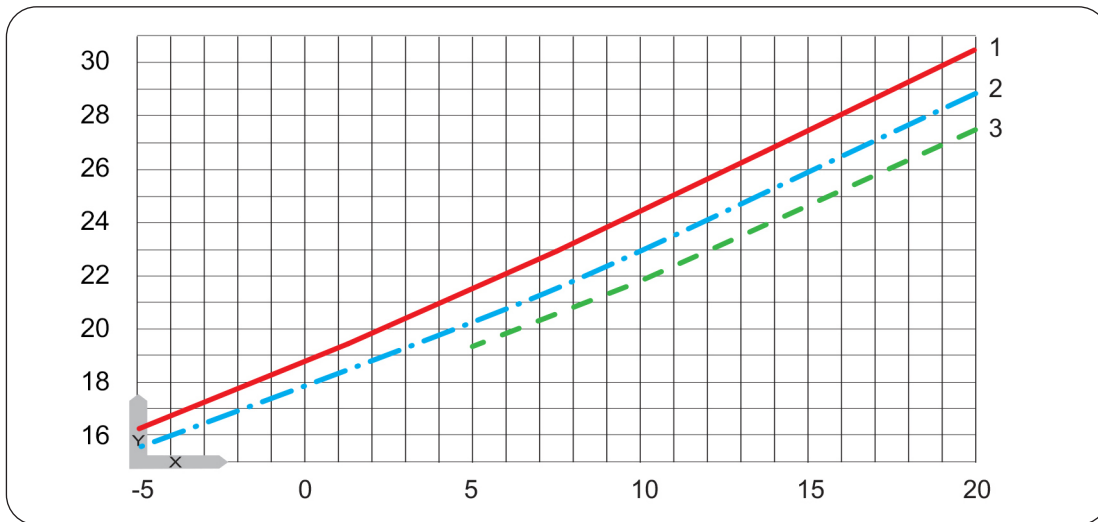

Power consumption HES ECO-G 20

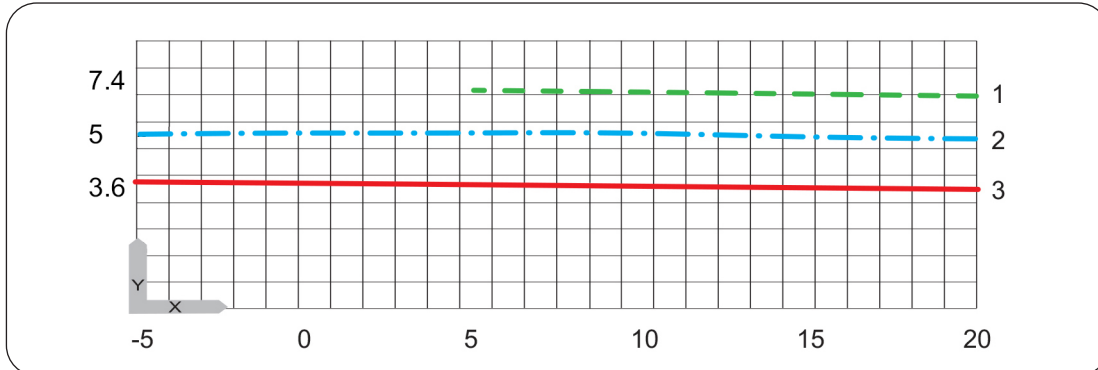

Power factor HES ECO-G 20

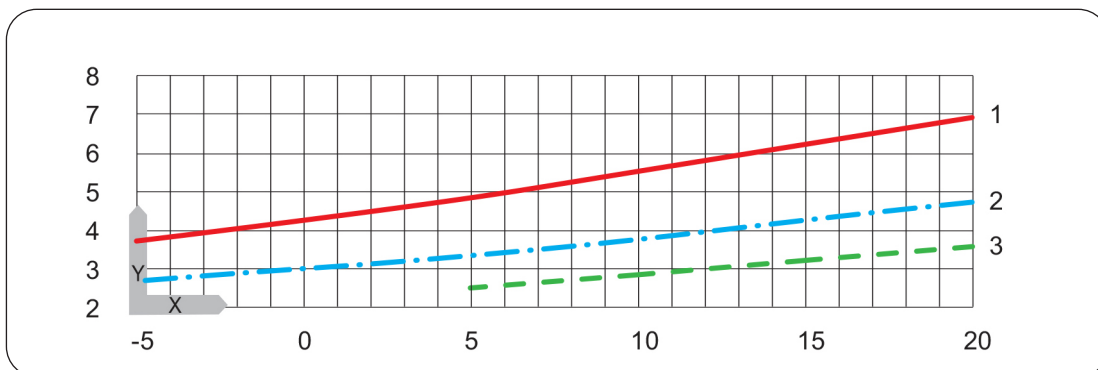

15.5 HES ECO-G 27 Power Diagram

Notation to the power diagram

Y Heating capacity [kW] / Power consumption [kW] / Power factor e [-]

X Inlet medium temperature WQA [°C]

1 Supply line temperature 35 °C, full load

2 Supply line temperature 50 °C, full load

3 Supply line temperature 58 °C, full load

Heating capacity HES ECO-G 27

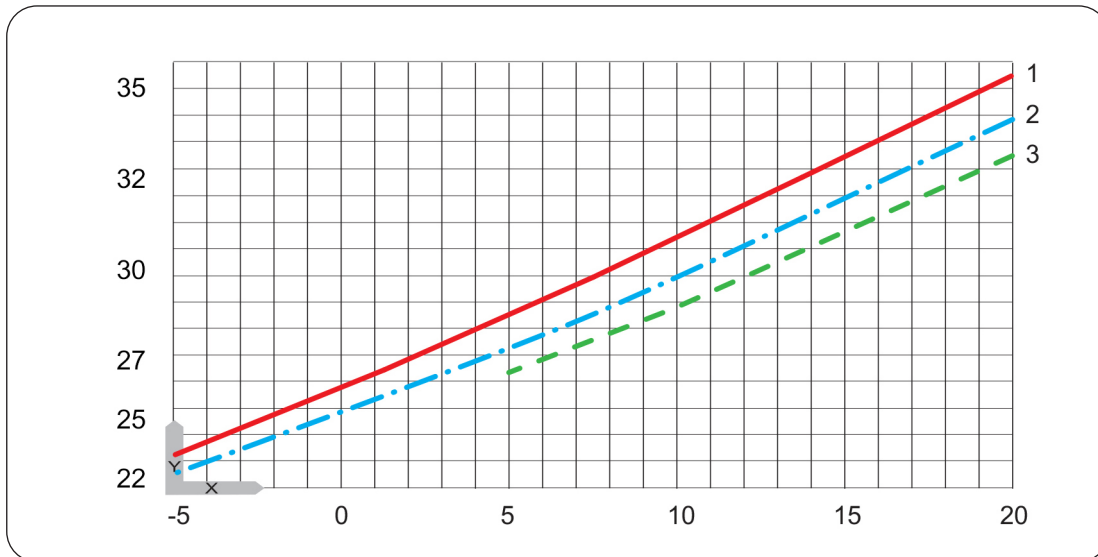

Power consumption HES ECO-G 27

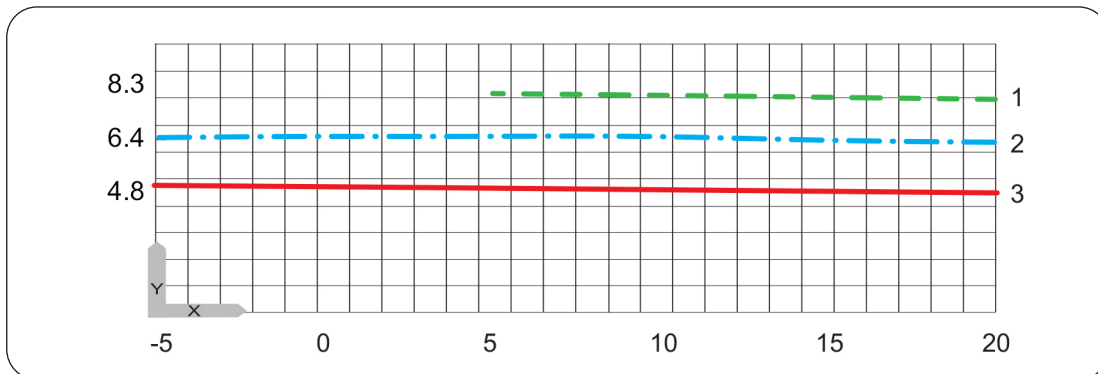

Power factor HES ECO-G 27

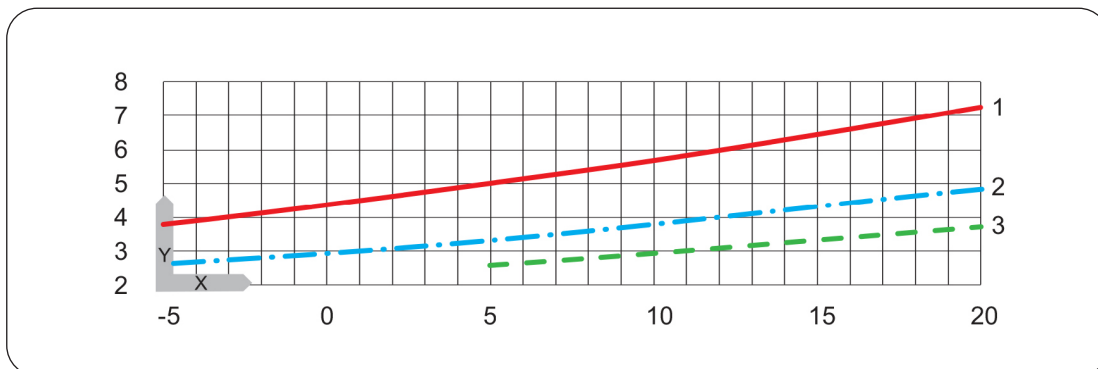

15.6 HES ECO-G 40 Power Diagram

Notation to the power diagram

Y Heating capacity [kW] / Power consumption [kW] / Power factor e [-]

X Inlet medium temperature WQA [°C]

1 Supply line temperature 35 °C, full load

2 Supply line temperature 50 °C, full load

3 Supply line temperature 58 °C, full load

Heating capacity HES ECO-G 40

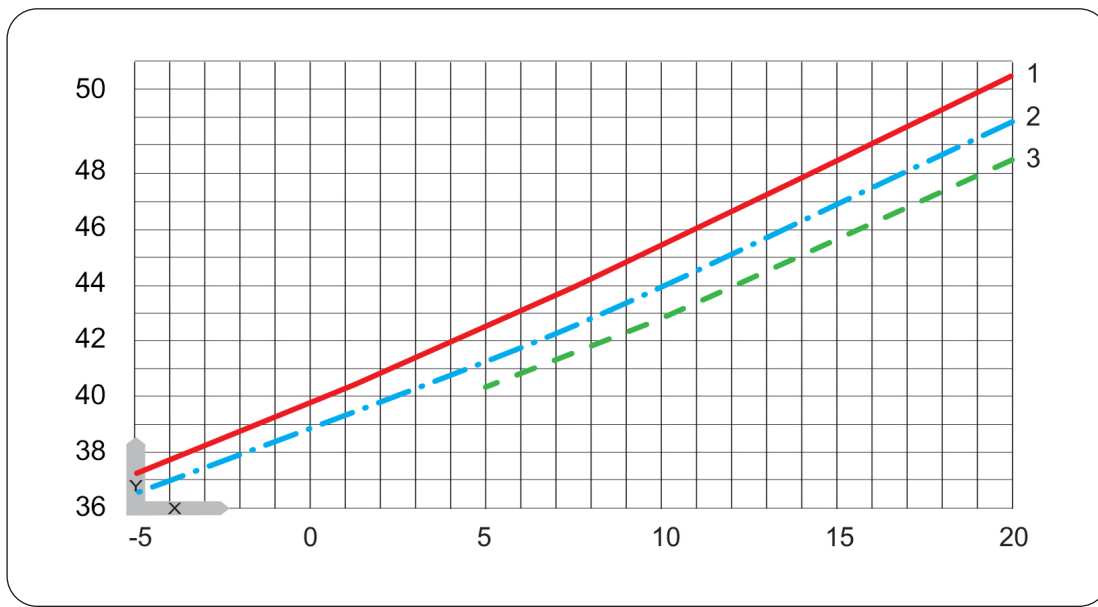

Power consumption HES ECO-G 40

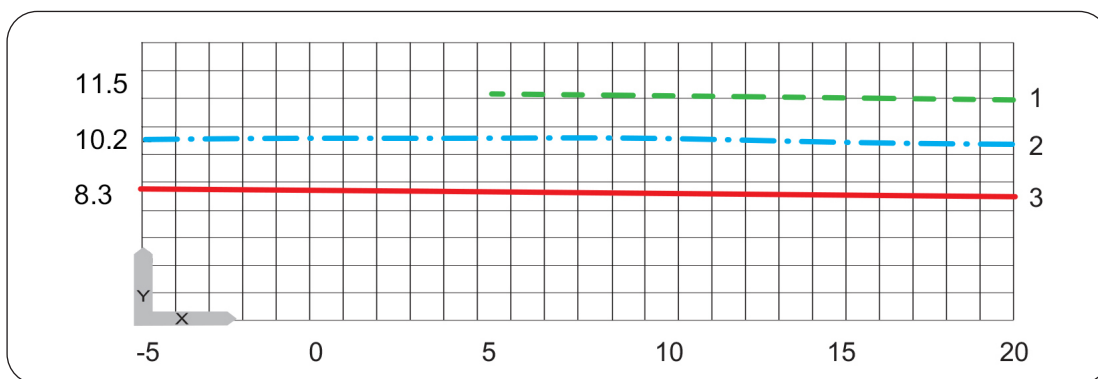

Power factor HES ECO-G 40

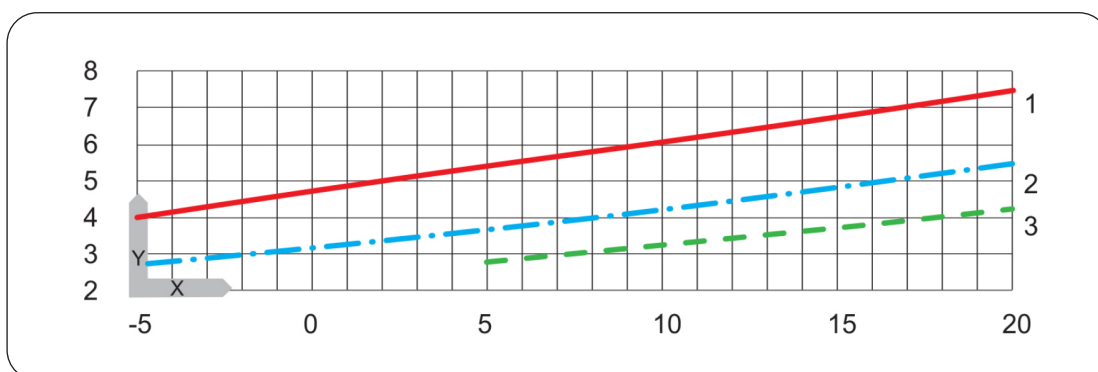

15.7 HES ECO-G 52 Power Diagram

Notation to the power diagram

Y Heating capacity [kW] / Power consumption [kW] / Power factor e [-]

X Inlet medium temperature WQA [°C]

1 Supply line temperature 35 °C, full load

2 Supply line temperature 50 °C, full load

3 Supply line temperature 58 °C, full load

Heating capacity HES ECO-G 52

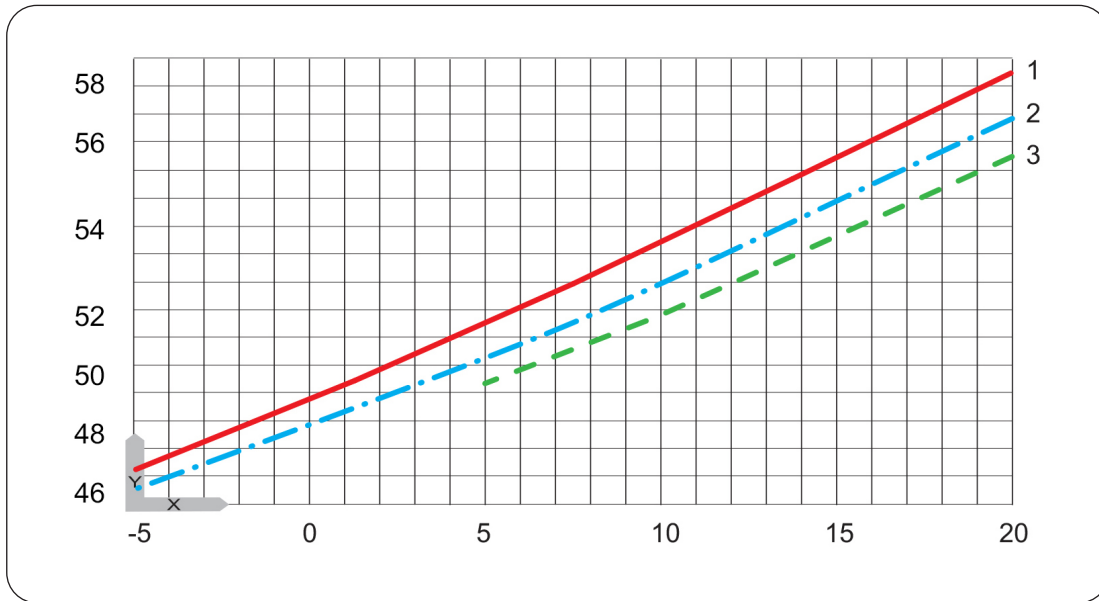

Power consumption HES ECO-G 52

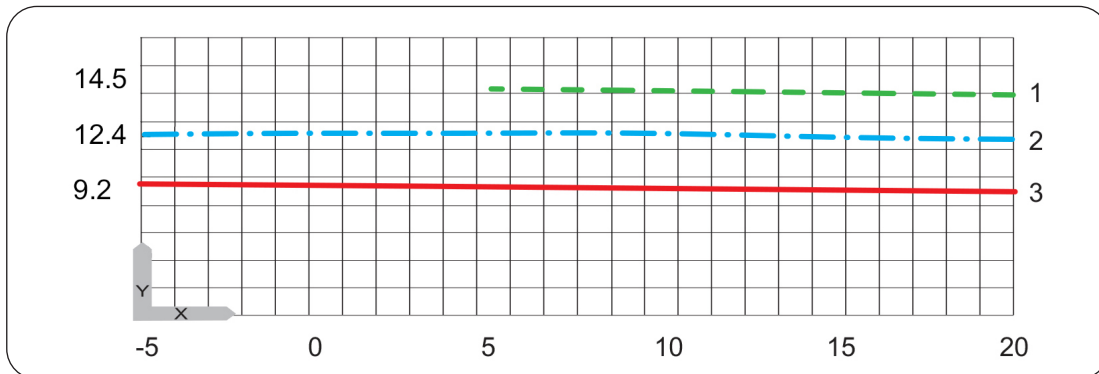

Power factor HES ECO-G 52

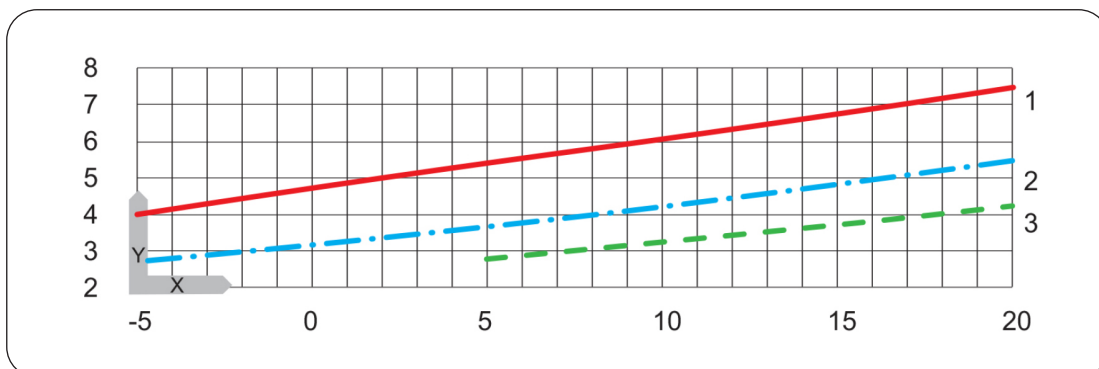

15.8 HES ECO-G 66 Power Diagram

Notation to the power diagram

Y Heating capacity [kW] / Power consumption [kW] / Power factor e [-]

X Inlet medium temperature WQA [°C]

1 Supply line temperature 35 °C, full load

2 Supply line temperature 50 °C, full load

3 Supply line temperature 58 °C, full load

Heating capacity HES ECO-G 66

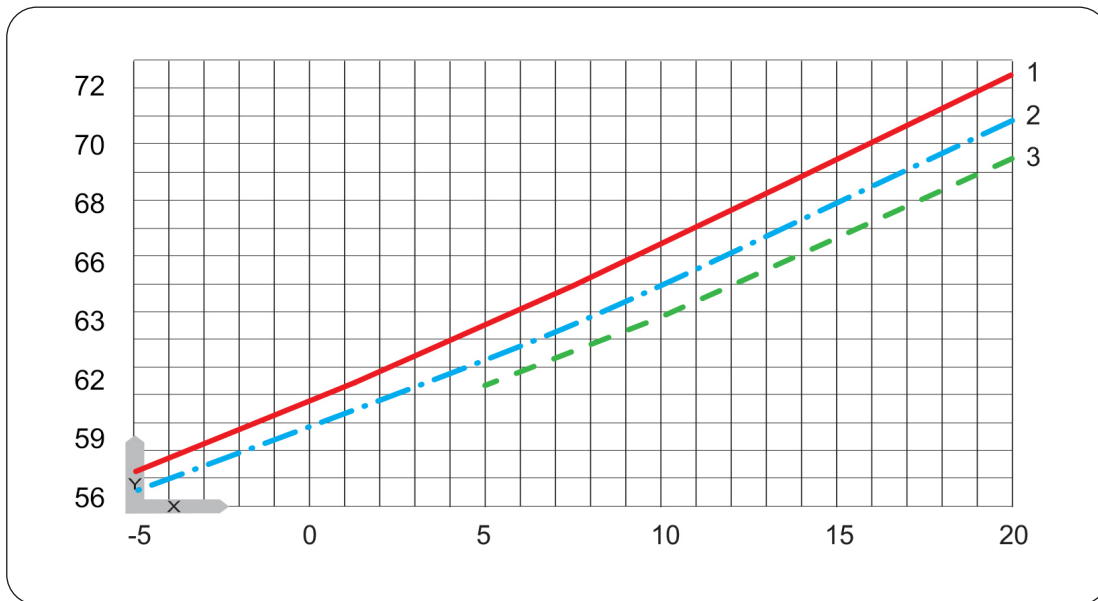

Power consumption HES ECO-G 66

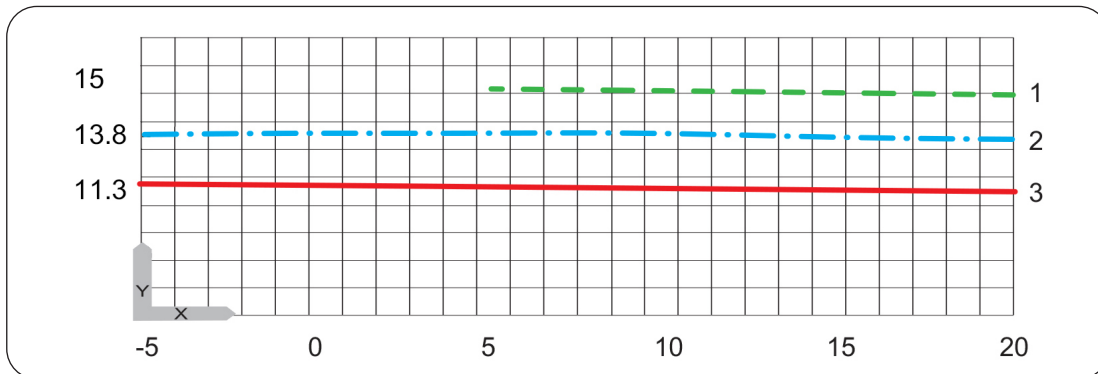

Power factor HES ECO-G 66

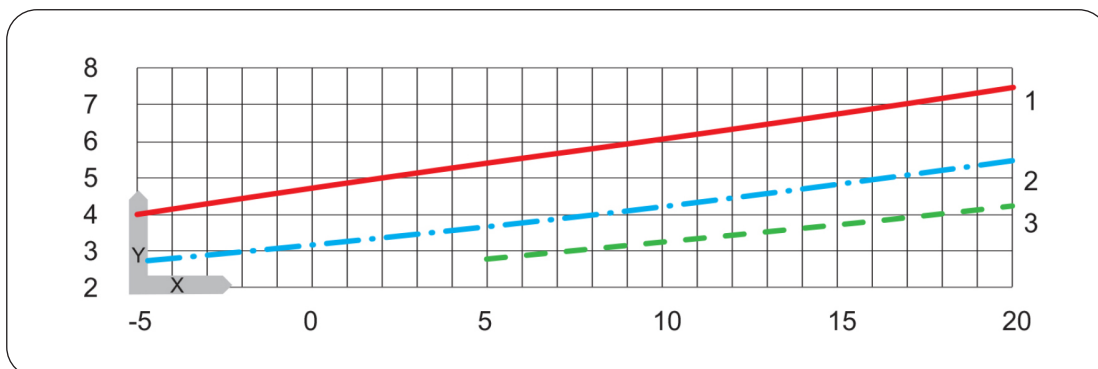

15.9 Parameter Table

The performance characteristics correspond to new devices whose heat exchangers are in a clean state.

		HES ECO-G 20	HES ECO-G 27	HES ECO-G 40
		G2001	G3001	G4001
Performance indicators				
Heating capacity B0/W35	kW	19,84	29,7	43
Power consumption B0/W35	kW	4,72	6,7	9,7
Coefficient of performance B0/W35		4,2	4,43	4,44
Heating capacity B0/W50	kW	18,58	28,00	39,60
Power consumption B0/W50	kW	7,06	10,14	13,34
Coefficient of performance B0/W50		2,63	2,77	2,97
Noise characteristics				
Sound pressure level at a distance of 1 m in an open area , not more than	dB(A)	48	48	49
Sound pressure level at a distance of 5 m in an open area , not more than	dB(A)	29	29	31
Limits of the operating range				
Max permissible pressure	MPa	0,3	0,3	0,3
The operating limit on the heating side is min	°C	20	20	20
The operating limit on the heating side is max	°C	58	58	58
The operating limit of the heat source is min	°C	-10	-10	-10
The operating limit of the heat source is max	°C	20	20	20
Electrical parameters				
Frequency	Hz	50	50	50
Fuse of the control circuit	A	1xC 10	1xC 16	1xC 16
Compressor fuse	A	3xC 35	3xC 35	3xC 35
Rated control voltage	V	230	230	230
Compressor rated voltage	V	400	400	400
Control phases		1/N/PE	1/N/PE	1/N/PE
Compressor phases		3/PE	3/PE	3/PE
Compressor input cable		5x6,0*	5x6,0*	5x6,0*
Heat exchangers				
Refrigerant		R410A	R410A	R410A
Evaporator material		stainless steel 1.4401/copper	stainless steel 1.4401/copper	stainless steel 1.4401/copper
Condenser material		stainless steel 1.4401/copper	stainless steel 1.4401/copper	stainless steel 1.4401/copper
Dimensions				
Height	mm	1800	1800	1800
Width	mm	600	600	600
Depth	mm	650	650	650
Weight indicators				
Weight	kg	420	440	480
Connections				
Connection of the heating line		2xD28 copper	2xD28 copper	2xD32 copper
Connection via the heat source line		2xD28 copper	2xD28 copper	2xD32 copper
Compressor				
Compressor type HES EMERSON		two HES 42	two HES 61	two HES 91
Technical specifications				
Flow rate in the heat source line	m ³ /h	5	7	10,5
Flow rate in the heating line	m ³ /h	7	10,5	13
Pressure drop, in the heating line	gPa	160	180	250
Pressure drop, heat source side	gPa	160	180	250

The performance characteristics correspond to new devices whose heat exchangers are in a clean state.

		HES ECO-G 52	HES ECO-G 66
		G5801	G6501
Performance indicators			
Heating capacity B0/W35	kW	50,4	65
Power consumption B0/W35	kW	11,18	14,36
Coefficient of performance B0/W35		4,51	4,53
Heating capacity B0/W50	kW	46,80	59,20
Power consumption B0/W50	kW	15,56	20,20
Coefficient of performance B0/W50		3,01	2,94
Noise characteristics			
Sound pressure level at a distance of 1 m in an open area , not more than	dB(A)	50	55
Sound pressure level at a distance of 5 m in an open area , not more than	dB(A)	35	35
Limits of the operating range			
Max permissible pressure	MPa	0,3	0,3
The operating limit on the heating side is min	°C	20	20
The operating limit on the heating side is max	°C	58	58
The operating limit of the heat source is min	°C	-10	-10
The operating limit of the heat source is max	°C	20	20
Electrical parameters			
Frequency	Hz	50	50
Fuse of the control circuit	A	1xC 16	1xC 16
Compressor fuse	A	3xC 50	3xC 50
Rated control voltage	V	230	230
Compressor rated voltage	V	400	400
Control phases		1/N/PE	1/N/PE
Compressor phases		3/PE	3/PE
Compressor input cable		5x10,0*	5x10,0*
Heat exchangers			
Refrigerant		R410A	R410A
Evaporator material		stainless steel 1.4401/copper	stainless steel 1.4401/copper
Condenser material		stainless steel 1.4401/copper	stainless steel 1.4401/copper
Dimensions			
Height	mm	1800	1800
Width	mm	600	600
Depth	mm	650	650
Weight indicators			
Weight	kg	540	580
Connections			
Connection of the heating line		2xD32 copper	2xD35 copper
Connection via the heat source line		2xD32 copper	2xD32 copper
Compressor			
Compressor type HES EMERSON		two HES 104	two HES 137
Technical specifications			
Flow rate in the heat source line	m ³ /h	13	16,1
Flow rate in the heating line	m ³ /h	9,2	11,5
Pressure drop, in the heating line	gPa	250	250
Pressure drop, heat source side	gPa	250	250

16. COMMISSIONING PROTOCOL



INSTRUCTION

In order to ensure the warranty of the product, the commissioning report must only be completed by a service engineer of an authorized dealer of the manufacturer, Home Electrical Systems Ltd.

A list of authorized dealers of the manufacturer is available on the website www.hes-hp.com.

1. Customer's address _____

2. The address of the installation company _____

3. Type of building

Single-family house	<input type="checkbox"/>	The heat pump comes separately	<input type="checkbox"/>
House for several families	<input type="checkbox"/>	Heat pump module	<input type="checkbox"/>
Residential building/small-scale production	<input type="checkbox"/>		
Industry/production	<input type="checkbox"/>		
Public Building	<input type="checkbox"/>		

4. Type of device

ID number _____

Order No. _____

Production number _____

5. Installing a heat pump

inside	<input type="checkbox"/>	on a concrete base	<input type="checkbox"/>
outside	<input type="checkbox"/>	on a ribbon foundation	<input type="checkbox"/>
basement	<input type="checkbox"/>	on a flat floor surface	<input type="checkbox"/>
horizontally	yes <input type="checkbox"/>	no <input type="checkbox"/>	
noise reduction	yes <input type="checkbox"/>	no <input type="checkbox"/>	

6. Installation and use instructions:

The volume of the installation room _____ m³

7. Work mode

monovalent	<input type="checkbox"/>	Bivalent heater	
- parallel	<input type="checkbox"/>	gas boiler	<input type="checkbox"/>
- partially parallel	<input type="checkbox"/>	oil tank	<input type="checkbox"/>
- alternative	<input type="checkbox"/>	solid fuel tank	<input type="checkbox"/>
		heat from the district heating system	<input type="checkbox"/>
		electric heating	<input type="checkbox"/>

8. Hydraulic coupling of a heat pump with a buffer storage

no yes Contents of the buffer storage _____

9. Water preparation

regardless from the heat pump	yes <input type="checkbox"/>	no <input type="checkbox"/>	with an external heat exchanger	yes <input type="checkbox"/>	no <input type="checkbox"/>	with an internal heat exchanger	yes <input type="checkbox"/>	no <input type="checkbox"/>
	yes <input type="checkbox"/>	no <input type="checkbox"/>		yes <input type="checkbox"/>	no <input type="checkbox"/>		yes <input type="checkbox"/>	no <input type="checkbox"/>

STE products: Types: _____

Foreign manufacturer: Types: _____

10. Heat source:

Air

Outdoor air	<input type="checkbox"/>	Temperature min _____ °C
Exhaust air	<input type="checkbox"/>	max _____ °C

Earth's heat probe Quantity _____

Nominal pipe diameter: _____

Distributor:		Tichelman connection
yes <input type="checkbox"/>	no <input type="checkbox"/>	yes <input type="checkbox"/> no <input type="checkbox"/>

Drilling depth: _____ Ground collector

Pipe length: _____

Nominal pipe diameter: _____

Surface: _____

Distributor:		Tichelman connection
yes <input type="checkbox"/>	no <input type="checkbox"/>	yes <input type="checkbox"/> no <input type="checkbox"/>

Coolant:

Type _____

Concentration _____

Frost protection border: _____

Water

Pit	<input type="checkbox"/>
Surface water	<input type="checkbox"/>

Other _____

11. Water distribution system:

Gender	<input type="checkbox"/>	Plates	<input type="checkbox"/>
Convectors	<input type="checkbox"/>	Radiators	<input type="checkbox"/>

Design temperature: VL °C _____ / RL _____ °C

12. Components of the device's peripherals:

Source circulation pump	Manufacturer/Type _____ / _____
Circulation pump of the heating system	Manufacturer/Type _____ / _____
Circulation pump Heat pump/Heat exchanger	Manufacturer/Type _____ / _____
Circulation pump Heat exchanger/Storage device	Manufacturer/Type _____ / _____
Circulation pump Heat exchanger/buffer storage	Manufacturer/Type _____ / _____
Circulation pump Hot water/circulation	Manufacturer/Type _____ / _____
Circulation pump Heat exchanger/Hot water tank	Manufacturer/Type _____ / _____
Mixing valve	Manufacturer/Type _____ / _____
Mixing valve actuator	Manufacturer/Type _____ / _____

13. Control device:

STE Product: Type: _____

Foreign manufacturer: Type: _____

Determination of parameters according to the control device commissioning protocol.

14. Electrical connection:

Type of conductivity: _____ **Управляющая линия теплового насоса:**

Number of wires: _____ Тип проводимости: _____

Diameter: _____ Количество жил: _____

Gasket according to VDE yes no Диаметр: _____

15. The measured value:

after 10 minutes of operation, it is measured on the heat pump

Salt solution/water/air inlet: _____°C Heat pump supply: _____°C

Output salt solution/water/air: _____°C Heat pump recirculation: _____°C

16. Control test according to VDE 0701:

Conducted: yes no

Values are normal: yes no

17. Equipment diagram

Place, date

Signature of the installation company representative

WARRANTY

Home Electro System guarantees the original owner the absence of defects in materials during the manufacture of the HES ECO-G heat pump for 24 (twenty-four) months. The warranty comes into force from the date of the commissioning protocol completion in the technical data sheet. If it is not filled in, it comes into force from the moment of sale by a certified trading organization and a mark on the warranty card. If the warranty card and the commissioning protocol are not filled in, it comes into force from the date of production.

The warranty does not apply in the following cases:

- ▶ Malfunction or damage as a result of installation, use, or repair that does not comply with the instructions and non-compliance with safety regulations.
- ▶ Malfunction or damage due to conditions not suitable for the purpose of using the equipment.
- ▶ Damage caused by negligence, accident, or force majeure.
- ▶ Malfunction or damage due to the use of unauthorized accessories. Repairs carried out during the warranty period must be approved before they are carried out by an authorized person. The warranty is cancelled if the equipment repair is carried out by a person unauthorized by Home Electric System.

The parts covered by the warranty must be replaced or repaired at the discretion of a certified Home Electric System dealer. Defective parts must be returned to the technical department. The warranty does not cover labor costs or unauthorized replacements. The return of a defective part is not covered by the warranty.

ENVIRONMENTAL PROTECTION AND RECYCLING

Contribute to environmental protection. The used materials should be disposed of in accordance with the norms.

This device is filled with R410A refrigerant.

The release of refrigerant R410A into the atmosphere is prohibited.

Russian Federation
Home Electro System

 info@hes-hp.com

 8 (800) 333 63 71
8 (4922) 49 47 70

 7, Novatorov str., Dobrograd 1 Special Economic Zone,
Kovrovsky district, Vladimir region, Russia